

Basics of Refrigeration

Dr. Harmesh Kumar
Deptt. of Mechanical Engineering

**Baba Banda Singh Bahadur Engineering
College, Fatehgarh Sahib**

**Refrigeration and
Air-Conditioning**

```
graph TD; A[Refrigeration and Air-Conditioning] --- B[Thermodynamics]; A --- C[Heat Transfer]; A --- D[Fluid Mechanics]
```

Thermodynamics

Heat Transfer

Fluid Mechanics

Refrigeration:

“Refrigeration is defined as “the process of achieving and maintaining the temperature of a region or bodies **lower than those available in the surroundings**”.

Refrigeration

What is the difference between cooling and refrigeration ?

Example:

- Cooling of a hot cup of coffee by leaving it on a table
- Cooling of a pot of water by mixing it with a large block of ice

Air Conditioning

“treatment of air so as to simultaneously control its

- temperature,
- moisture content,
- quality and
- circulation

as required by **occupants, a process, or products in the space**”.

Relation between Refrigeration and Air conditioning

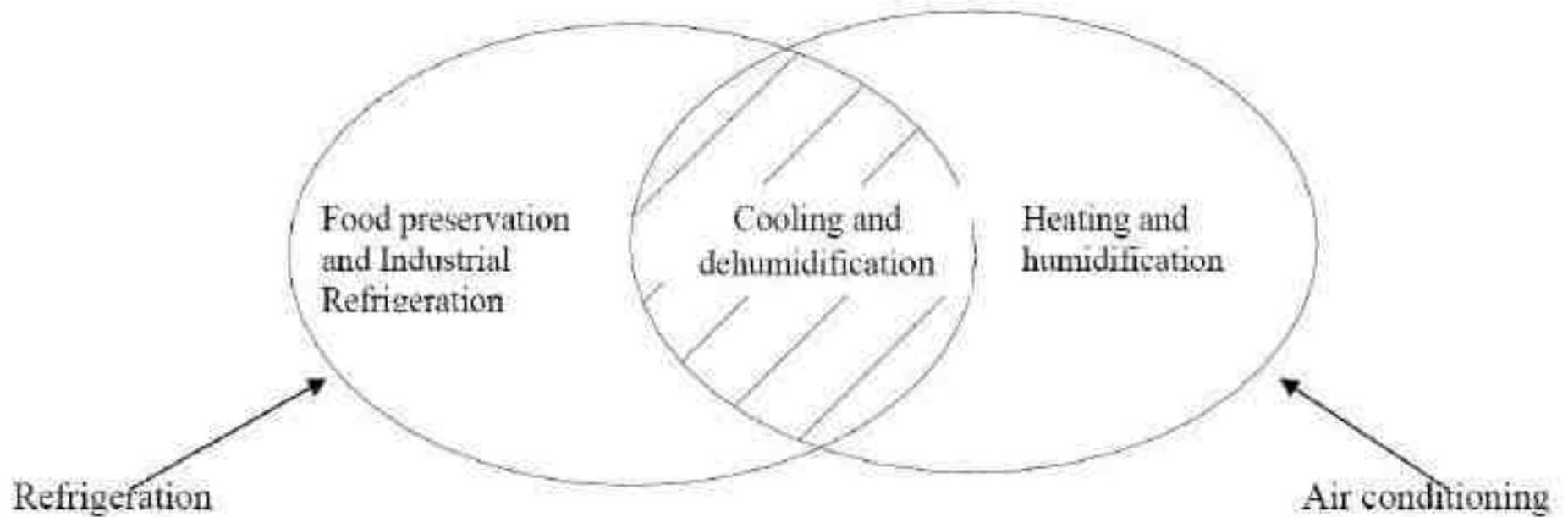

Refrigerator

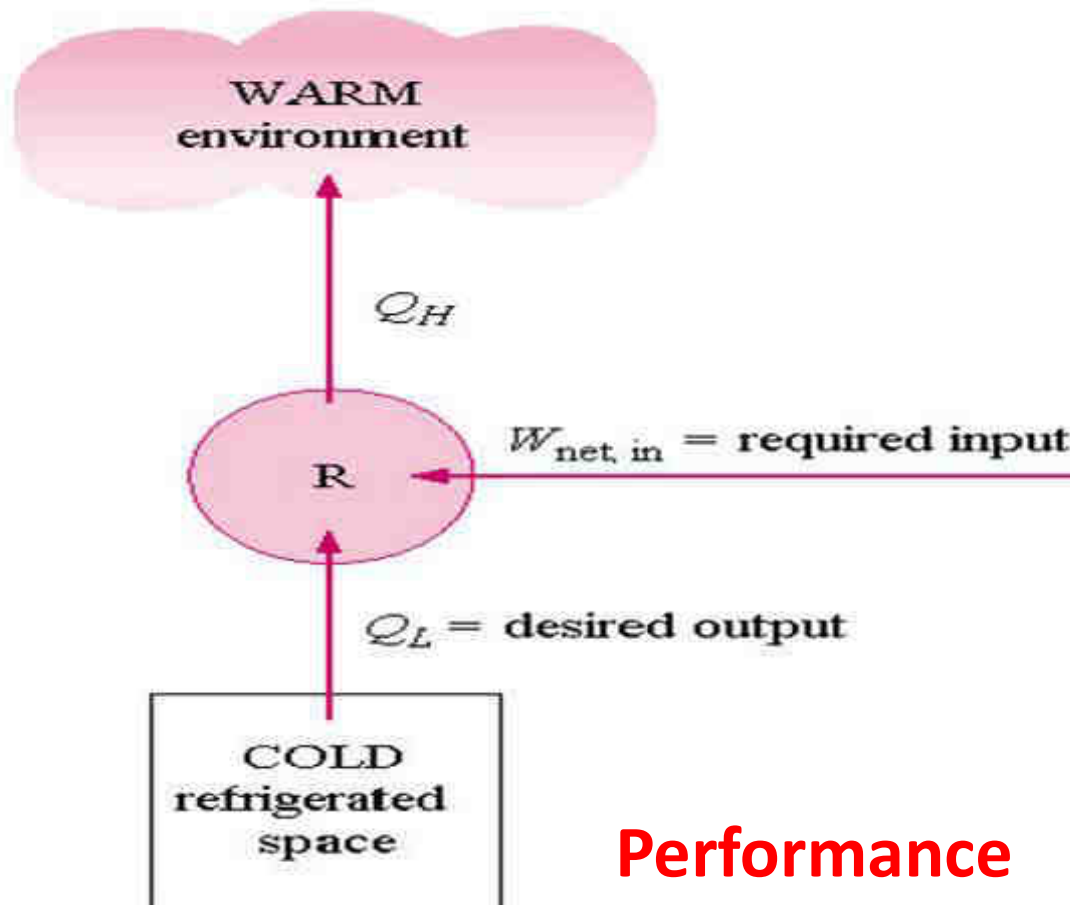

Performance

COP = Refrigerating effect/Work input

Ton of Refrigeration (TR):

- Originally 1 TR was defined as the rate of heat transfer required to make 1 ton of ice per day from water at 0°C.
- 1 ton of refrigeration
 - = $(335 * 1000) / (24 * 60) = 232.62 \text{ kJ/min}$
 - = 210 kJ/min or = 3.5 kW
- Unit of Refrigerating Capacity

Specifications of domestic refrigerator

ENERGY IS LIFE
BEE
CONSERVE IT

Understanding Energy Label for Refrigerator

Energy Star Rating of Refrigerator: 1 Star is less efficient and 5 Star is more efficient

Energy Saved is Money saved

Annual Energy Consumption (in kWh) under tested conditions

Product Details with type of Refrigerator (FF / DC)

Volume in liters (Gross Volume)

Volume in liters Usable Storage Volume)

BEE Logo Authenticity of the label

Test Conditions as specified by the Bureau of Energy Efficiency

POWER SAVINGS GUIDE

ELECTRICITY CONSUMPTION
580*
UNITS PER YEAR

Appliance	Refrigerator
Brand	ABC
Model	XYZ 27W2007
Type	Frost Free
Gross volume	270 liters
Storage volume	200 liters

ENERGY IS LIFE
BEE
CONSERVE IT

5/8/2009

*Under test conditions, when tested in accordance with IS:1329. Actual electricity consumption will depend on how the appliance is being used.

Specifications of domestic refrigerator

- **Gross Volume** - Measured volume enclosed within a compartment. While determining gross volume, internal fittings like shelves, removable partitions, containers, evaporator, thermostat & internal light housings are believed as not in place.
- **Storage Volume** – gross volume of a compartment minus the volumes of components & spaces recognized as being unusable for food storage. When the storage volume is determined, internal fittings like shelves, removable partitions, containers, evaporator, thermostat & internal housings are believed to be in place.

Specifications of domestic refrigerator

Type of Refrigerator

- **Direct Cool (DC) Refrigerator**

- With or without ice making or frozen food storage compartments
- Cooling is primarily obtained by **natural convection** only.

- **Frost Free (FF) Refrigerator**

- Cooling is provided by **forced air circulation**.
- All frozen food storage space is cooled by a **frost-free system**

Specifications of domestic refrigerator

ENERGY IS LIFE
BEE
CONSERVE IT

Understanding Energy Label for Refrigerator

Energy Star Rating of Refrigerator: 1 Star is less efficient and 5 Star is more efficient

Energy Saved is Money saved

Annual Energy Consumption (in kWh) under tested conditions

Product Details with type of Refrigerator (FF / DC)

Volume in liters (Gross Volume)

Volume in liters Usable Storage Volume)

BEE Logo Authenticity of the label

Test Conditions as specified by the Bureau of Energy Efficiency

POWER SAVINGS GUIDE

ELECTRICITY CONSUMPTION
580*
UNITS PER YEAR

Appliance	Refrigerator
Brand	ABC
Model	XYZ 27W2007
Type	Frost Free
Gross volume	270 liters
Storage volume	200 liters

ENERGY IS LIFE
BEE
CONSERVE IT

5/8/2009

*Under test conditions, when tested in accordance with IS:1509. Actual electricity consumption will depend on how the appliance is being used.



Energy Star Levels for Refrigerators

- Measured Energy consumed (E_n) is then located amongst the 5 Star Slab values to arrive at the Star Rating of that refrigerator as per criteria below :
 - 1 Star < E_n < 2 Star = 1 Star
 - 2 Star < E_n < 3 Star = 2 Star
 - 3 Star < E_n < 4 Star = 3 Star
 - 4 Star < E_n < 5 Star = 4 Star
 - E_n > 5 Star = 5 Star
- **1 Star is least efficient while 5 Star is most efficient.**

Meaning of Star Rating

- As per Bureau of Energy Efficiency, India

If we assume **no star rated Air Conditioner** consumes - **100 units**, See how will the star rated AC'S Consume

1 star - 95 units (5% savings)
2 star - 88 units (12% savings)
3 star - 81 units (19% savings)
4 star - 76 units (24% savings)
5 star - 71 units (29% savings)

If we assume **no star rated Refrigerator** consumes - **1100 units per Year** , See how will the star rated Refrigerators consume ?

1 star - 977 units (12% savings)
2 star - 782 units (29% savings)
3 star - 626 units (44% savings)
4 star - 501 units (55% savings)
5 star - 400 units (64% savings)

Above figures indicate Star rated Refrigerators are really conservative, where a 5 Star Refrigerator can **SAVE** up to 64 percent while 5 star AC can **SAVE** up to 29%

Thanks!

Units and Applications of Refrigeration & Air-Conditioning

Dr. Harmesh Kumar
Deptt. of Mechanical Engineering

**Baba Banda Singh Bahadur Engineering
College, Fatehgarh Sahib**

Units of Refrigeration

Freezing and Melting

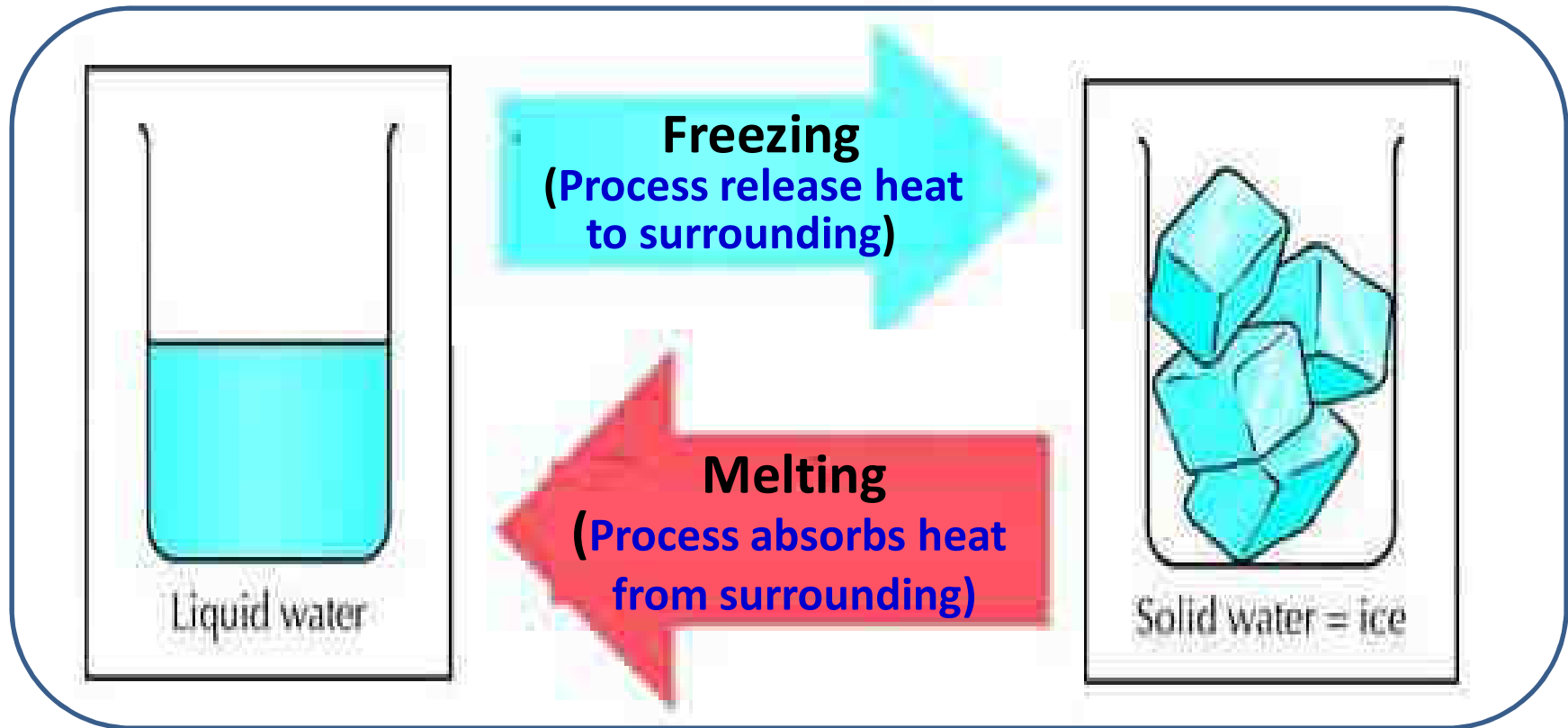

Units of Refrigeration

Ton of Refrigeration (TR)

1 TR means the rate of heat removal required to make
1 ton of ice per day from water at 0°C

Total heat to be removed = 1000×335 kJ

Time allowed = 24×60 min

Heat removal rate = $(1000 \times 335) / (24 \times 60)$
= 232 kJ /min

System removing heat at the rate of 232 kJ/min
known as one TR system

Applications of Refrigeration & Air-Conditioning

Applications

- Food processing, preservation and distribution
- Chemical and process industries
- Special application
- Comfort air conditioning

Refrigeration in food processing, preservation and distribution

- Food preservation is one of the classical and most important applications of refrigeration
- It is well known that food products can be preserved for longer time, if stored at **low temperatures**
- Both **live products** as well as **dead products** can be preserved for longer time using refrigeration

Cont...

- Live products (e.g. fruits, vegetables)
- These products get spoiled due to:
 - **Bacterial activity, and**
 - **Enzymatic processing**
- Dead products such as fish, meat get spoiled due to bacterial activity
- **The growth of bacteria and the rate of enzymatic processes are reduced at low temperature.**

Effect of storage on useful storage life of food products

Food Product	Average useful storage life (days)		
	0°C	22°C	38°C
Meat	6-10	1	<1
Fish	2-7	1	<1
Poultry	5-18	1	<1
Dry meats and fish	>1000	> 350 & < 1000	> 100 & < 350
Fruits	2 - 180	1 - 20	1 - 7
Dry fruits	> 1000	> 350 & < 1000	> 100 & < 350
Leafy vegetables	3 - 20	1 - 7	1 - 3
Root crops	90 - 300	7 - 50	2 - 20
Dry seeds	> 1000	> 350 & < 1000	> 100 & < 350

Recommended storage condition for food and vegetables

	Storage Temperature, °C	Relative Humidity, %	Maximum, recommended storage time	Storage time in cold storages for vegetables in tropical countries
Apples	0 - 4	90 - 95	2 - 6 months	-
Beetroot	0	95 - 99	4 - 6 months	
Cabbage	0	95 - 99	5 - 6 months	2 months
Carrots	0	98 - 100	5 - 9 months	2 months
Cauliflower	0	95	3 - 4 weeks	1 week
Cucumber	10 - 13	90 - 95	10 - 14 days	
Eggplant	8 - 12	90 - 95	7 days	
Lettuce	0	95 - 100	2 - 3 weeks	
Melons	7 - 10	90 - 95	2 weeks	
Mushrooms	0 - 4	95	2 - 5	1 day
Onions	0	65 - 70	6 - 8 months	
Oranges	0 - 4	85 - 90	3 - 4 months	
Peas, Green	0	95 - 98	1 - 2 weeks	
Pears	0	90 - 95	2 - 5 months	
Potatoes	4 - 16	90 - 95	2 - 8 months	
Pumpkin	10 - 13	70 - 75	6 - 8 months	
Spinach	0	95	1 - 2 weeks	1 week
Tomatoes	13 - 21	85 - 90	1 - 2 weeks	1 week

Cold Chain

- For effective preservation of food products a cold chain is required
 1. Refrigeration for post-harvest treatment
 2. Refrigerated transport
 3. Refrigeration during food processing
 4. Cold storage for storing food
 5. Refrigeration at retail supermarkets etc.
 6. Refrigeration at end's user place

Ammonia based refrigerant plant for large cold storage



Benefits of cold chain

- Reduced food spoilage
- Excess crop of fruits and vegetables can be stored for use during peak demands and during off season
- Food products can be made available in places where they are not grown
- Distress selling by farmers during on season can be prevented

Photograph of typical cold storage



Cont....

- Domestic refrigerator has become an essential kitchen appliance in almost all households
- Supermarket refrigeration
- Refrigeration is also required in remote and rural areas for preservation of farm products, dairy products

Supermarket with refrigerated display cases



- **Conditions required for storage of food products vary from product to product**
- The storage life depends on:
 - 1. The type of product stored**
 - 2. Temperature**
 - 3. Humidity**
 - 4. Air velocity inside the cold storage**
 - 5. Initial quality of food products**

Applications of refrigeration in chemical and process industries

- For separation and liquefaction of gases in petrochemical industries and refineries
- For removal of heat of reaction in various chemical industries
- For dehumidification of process air in pharmaceutical industries etc.

Special applications of refrigeration

Manufacturing:

- Cold treatment of metals in the manufacture of precision parts, cutting tools to improve:
 - Dimensional accuracy
 - Hardness, wear resistance and tool life

Medicals:

- For storage of blood plasma, tissues etc.
- For manufacturing and storage of drugs
- For storage of vaccines, medicines in remote and rural area

In construction: for setting of concrete

Manufacturing of ice

Applications of air conditioning

- Air conditioning is required for
 - Providing thermal comfort to humans and other living beings- **Comfort air conditioning**
 - Providing conditions required for various products and processes in industries- **Industrial air conditioning**

Industrial air conditioning

- Computer rooms
- Power plants
- Laboratories
- Printing
- Manufacturing of precision parts
- Textiles industry
- Pharmaceutical industries
- Photographic Material
- Farm animals
- Vehicular air conditioning

Comfort air conditioning

- Residences, offices etc
- Hospitals
- Supermarket, stores, shopping centers etc.
- Restaurants, theatres ,auditorium and other amusement places
- Large commercial buildings

All have slightly different requirements and different design

Rapid Growth of Refrigeration Technology

The rapid growth of refrigeration technology can be attributed to several reasons, some of them are:

- **Growing global population** leading to growing demand for food, hence, demand for better food processing and food preservation methods.
- **Growing demand for refrigeration in almost all industries**

Rapid Growthcont.

- **Growing demand for comfortable conditions** (air conditioned) at residences, workplaces etc.
- **Rapid growth of technologies** required for manufacturing various refrigeration components
- **Availability of electricity**, and
- **Growing living standards**

THANKS!
THANKS!

EXPANSION DEVICES

Expansion Devies: Types

- Capillary tube
- Thermostatic expansion valve
- Solid state expansion valve
- Automatic expansion valve
- Solenoid expansion valve

EXPANSION (METERING) DEVICES

- Meters the correct amount of refrigerant to the evaporator
- Installed in the liquid line at the inlet of the evaporator
- Common devices: Automatic expansion valve, thermostatic expansion valve, fixed bore (capillary tube)
- Less common devices: High-side float, low-side float

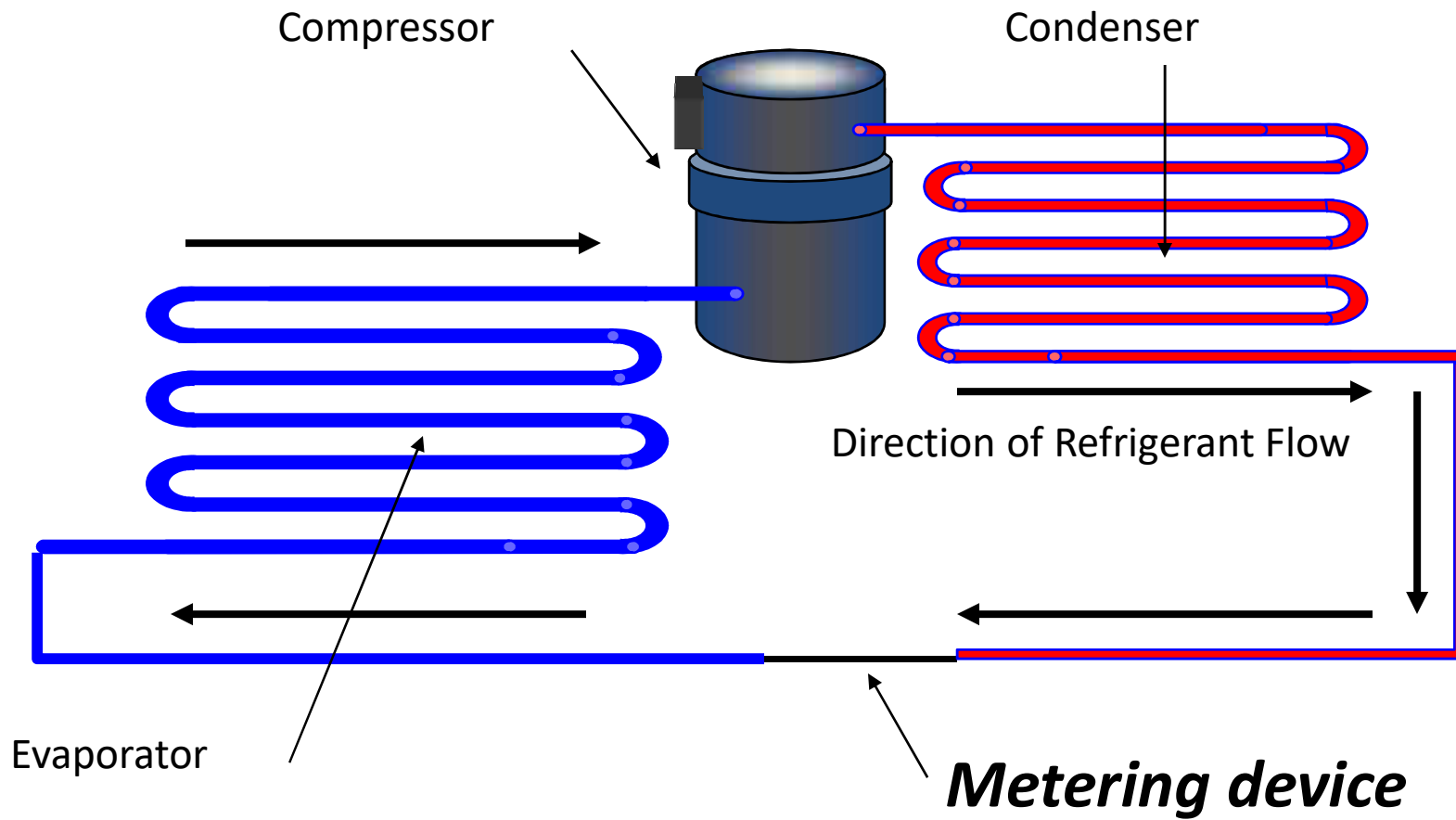

THERMOSTATIC EXPANSION VALVE (TXV)

- ▣ Maintains a constant evaporator superheat
- ▣ If the evaporator superheat is high, the valve will open
- ▣ Superheat ensures that no liquid refrigerant leaves the evaporator
- ▣ Low superheat increases the net refrigerant effect

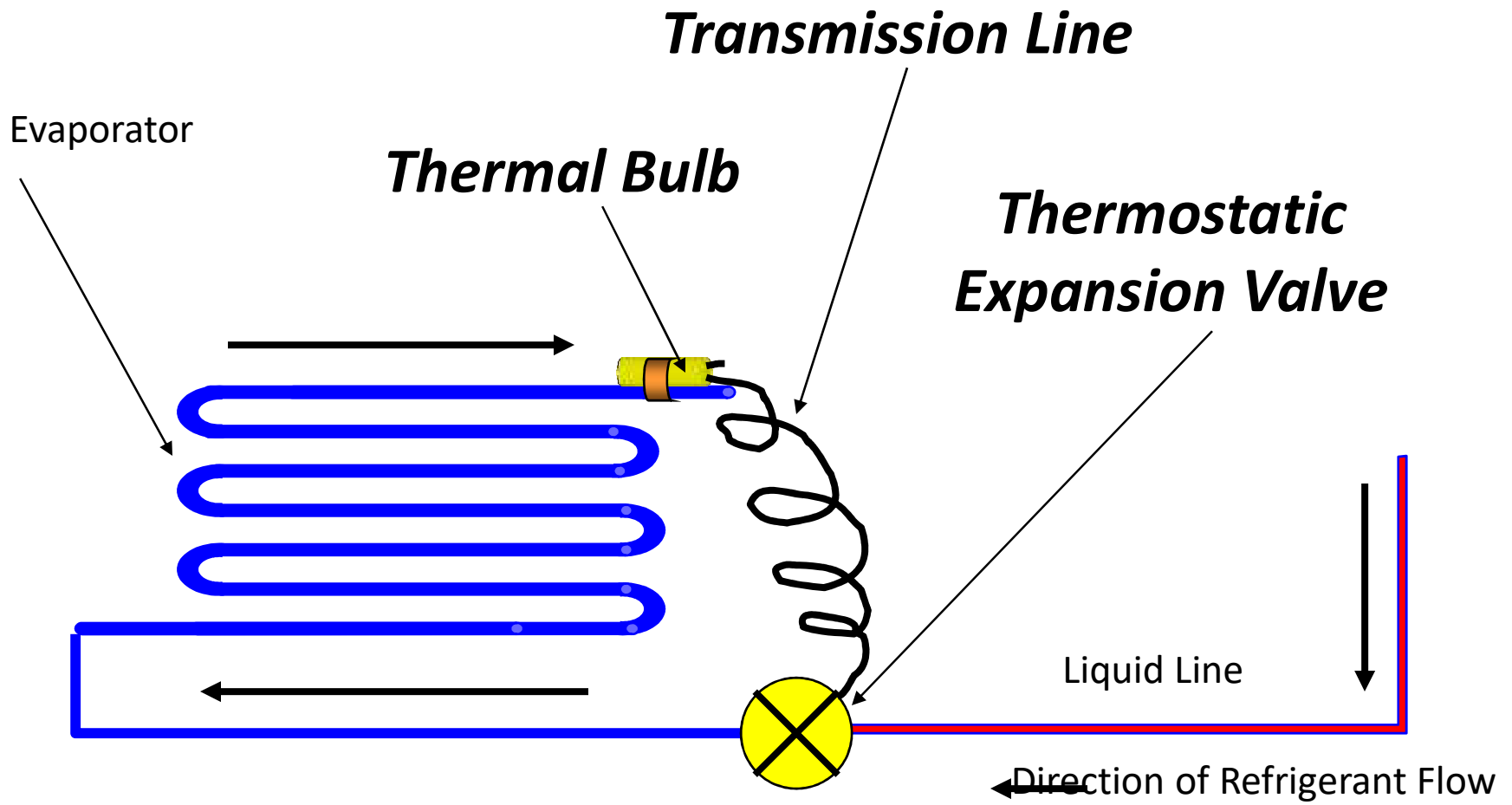

TXV COMPONENTS

- ▣ Valve body
- ▣ Diaphragm
- ▣ Needle and seat
- ▣ Spring
- ▣ Adjustment and packing gland
- ▣ Sensing bulb and transmission tube

THE VALVE BODY

- ▣ Machined brass or stainless steel
- ▣ Holds components together
- ▣ Provides means to connect valve to the piping circuit
- ▣ Fastened by flare, solder, or flange
- ▣ Has an inlet screen to stop any small particulate matter from entering valve

THE DIAPHRAGM

- ▣ Moves the needle in and out of the seat in response to system load changes
- ▣ Flexes downward to open the valve
- ▣ Flexes upward to close the valve
- ▣ Made of thin, flexible stainless steel
- ▣ Located at the top of the valve

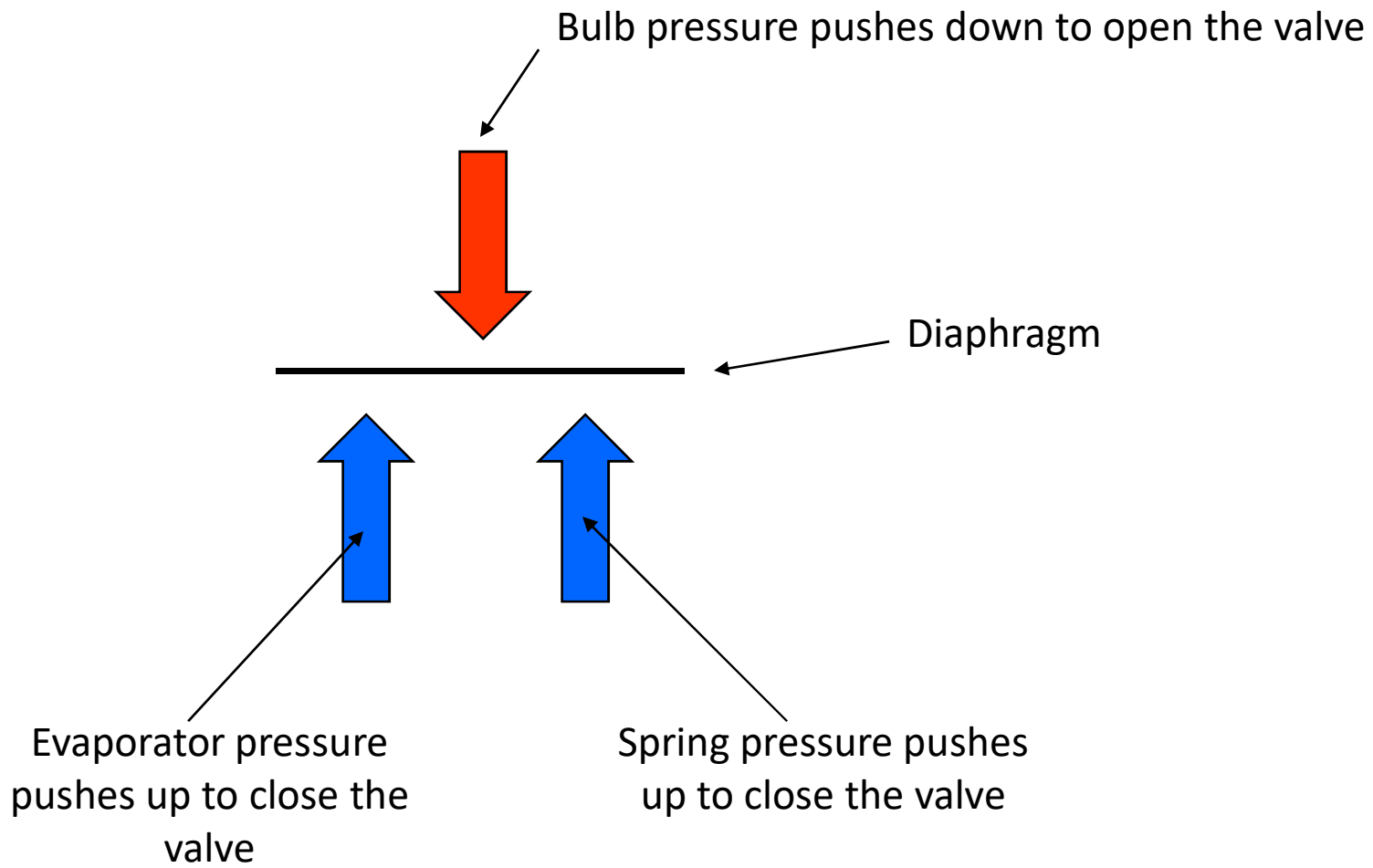

NEEDLE AND SEAT

- ▣ Control refrigerant flow through the valve
- ▣ Needle is pushed into the seat to reduce refrigerant flow to the evaporator
- ▣ Made of stainless steel
- ▣ The greater the pressure difference across the needle and seat, the greater the amount of flow through the valve

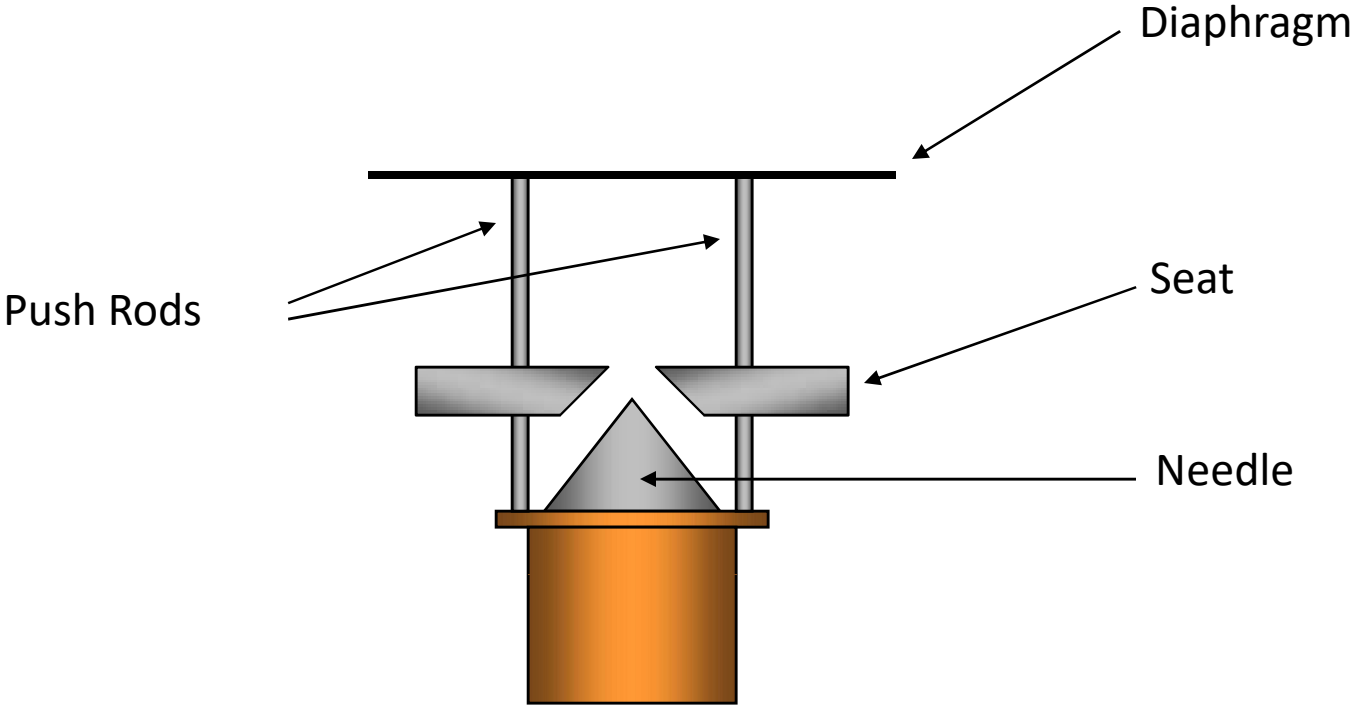

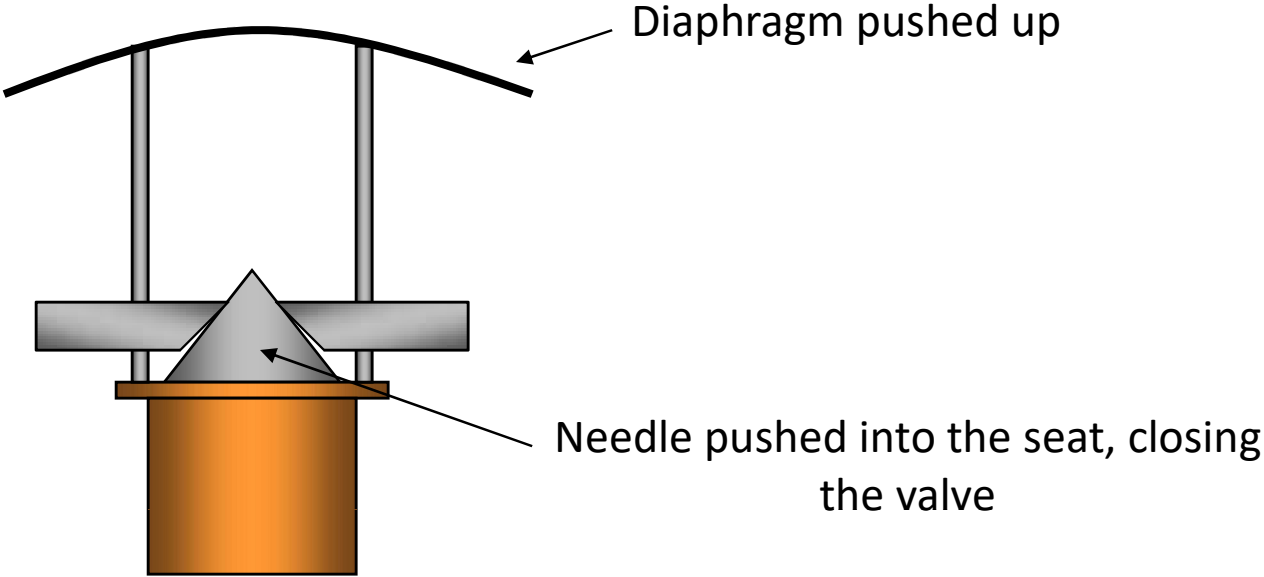

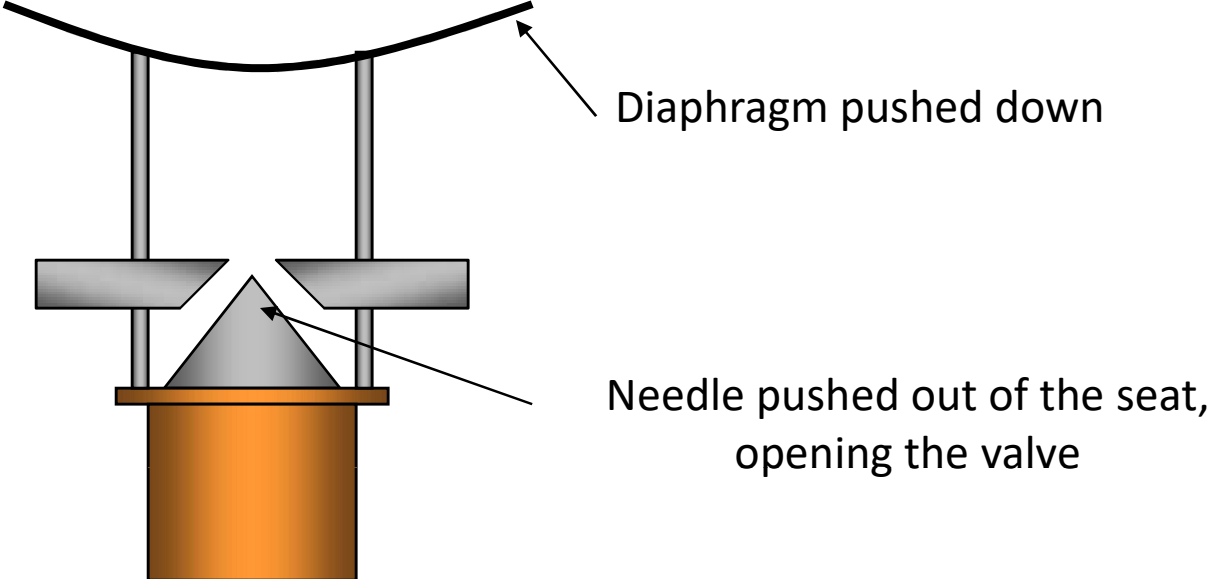

THE SPRING

- One of the valve's closing forces
- Acts to push the needle into the seat, causing the valve to close
- Spring pressure determines the evaporator superheat
- Spring tension can be field adjusted
- Only EXPERIENCED field technicians should do adjustments on the valve

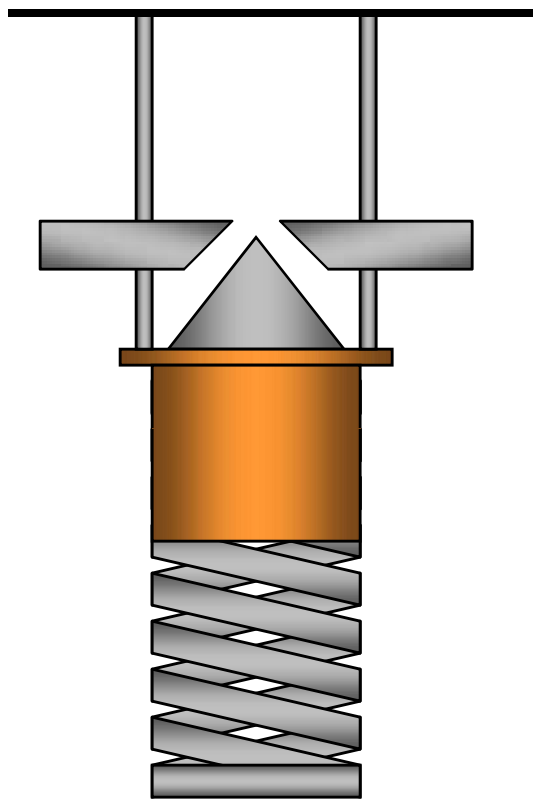

The spring pushes up on the push rods to close the valve

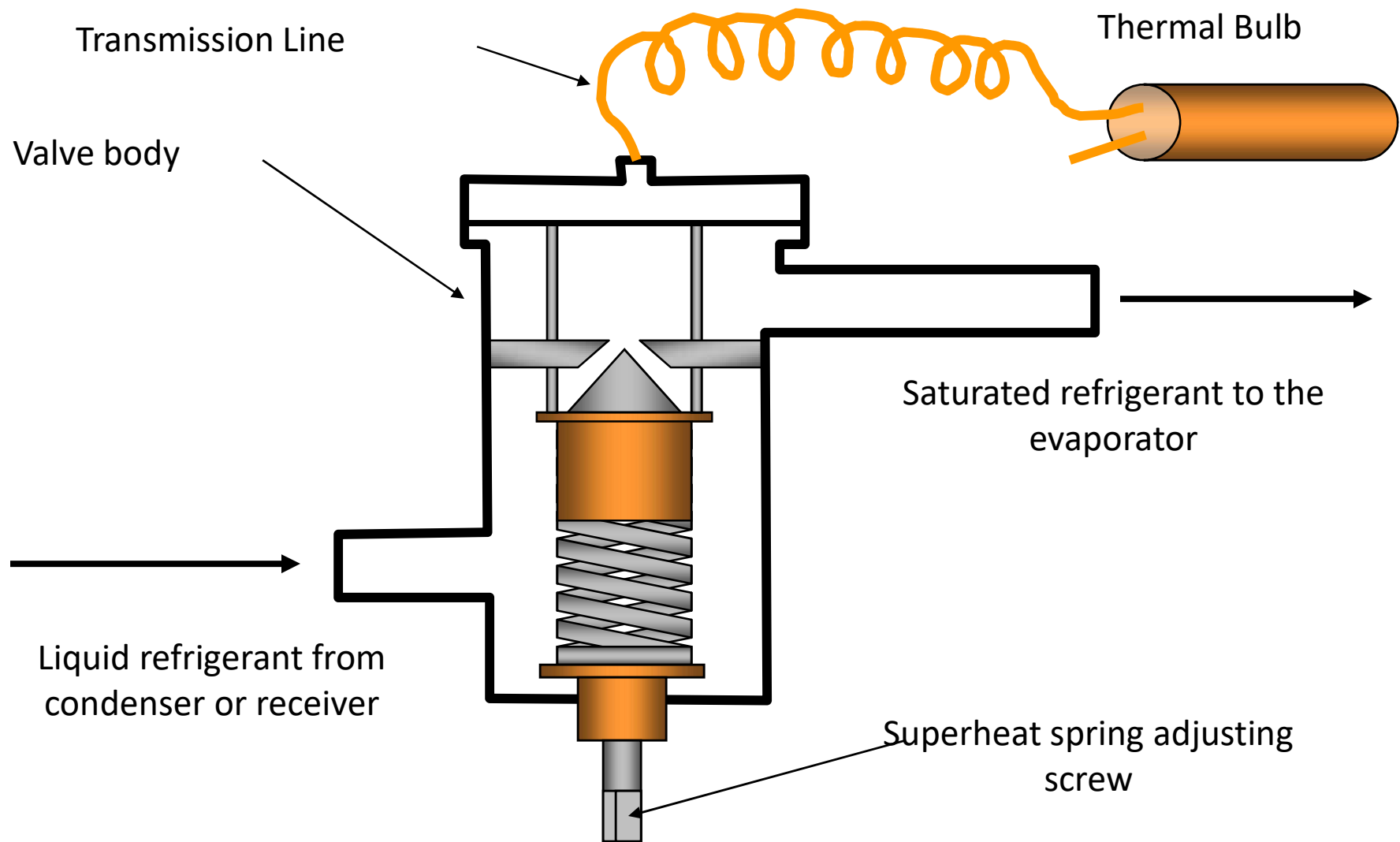

LOAD CHANGES WITH FOOD ADDED TO COOLER

- Addition of warm food increases evaporator load
- Refrigerant boils faster and suction pressure rises
- Evaporator superheat rises
- Valve opens to feed more refrigerant to the evaporator
- Increased evaporator superheat causes temperature of remote bulb to rise

LOAD CHANGES WITH FOOD REMOVED FROM THE COOLER

- Removal of food reduces load on the evaporator
- Refrigerant boils slower and suction pressure drops
- Evaporator superheat drops
- Valve closes to feed less refrigerant to the evaporator

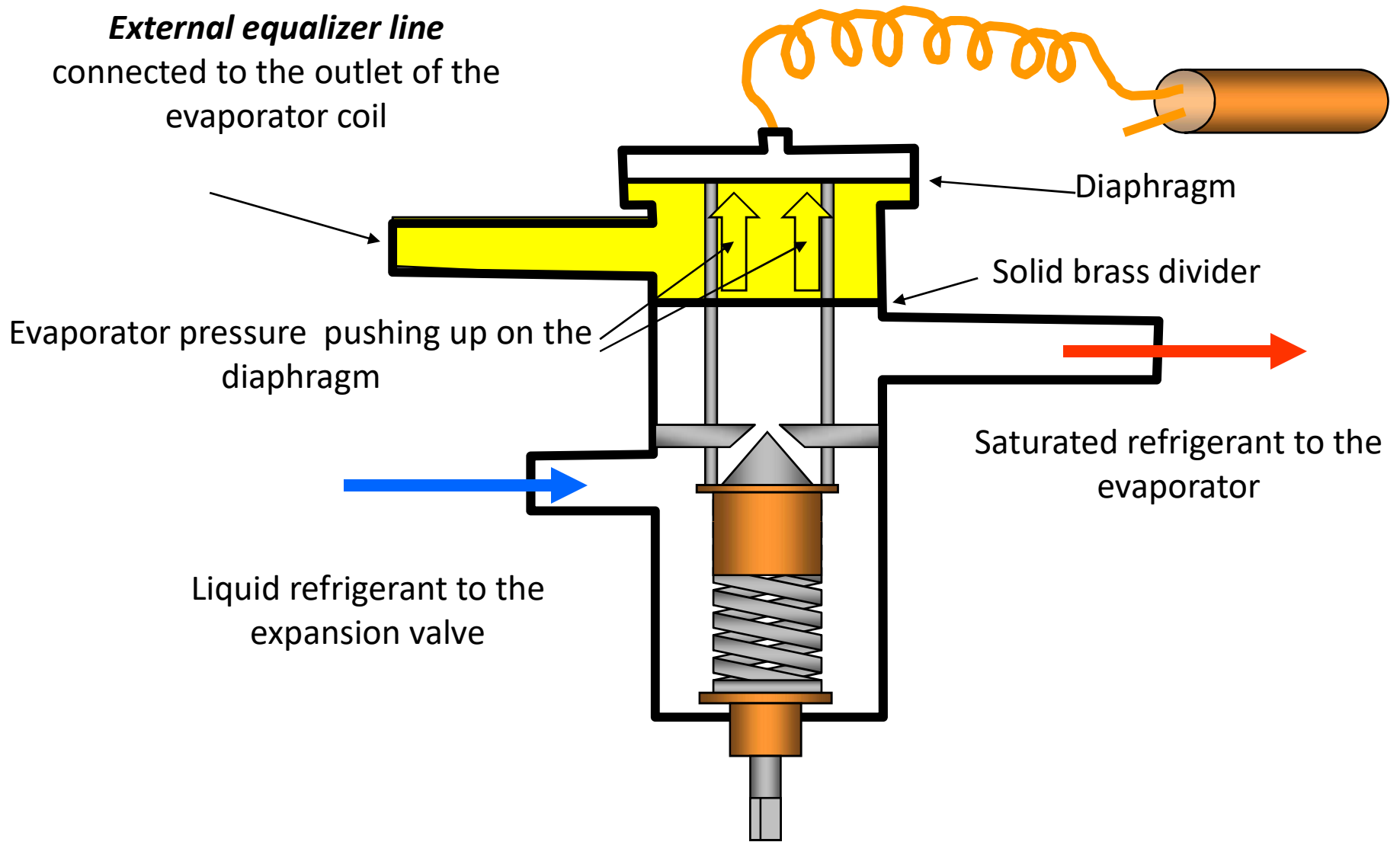

THE SOLID-STATE CONTROLLED EXPANSION VALVE

- Uses a thermistor as a sensing element
- Electrically controlled
- When coil is energized, the valve opens
- Responds very quickly to temperature changes
- Suitable for heat pump applications

STEP MOTOR EXPANSION VALVES

- Uses a small motor to control the valve port
- Valve port controls evaporator superheat
- Temperature sensor sends a signal to the controller
- The controller sends a signal to the motor
- signal The motor turns a fraction of a rotation for each controller

AUTOMATIC EXPANSION VALVE

- Maintains constant pressure in the evaporator
- When the evaporator pressure drops, the valve opens
- The spring pressure pushes to open the valve
- The evaporator pressure pushes to close the valve
- Turning the adjustment screw into the valve increases the spring pressure

Spring pressure pushes down to open the valve

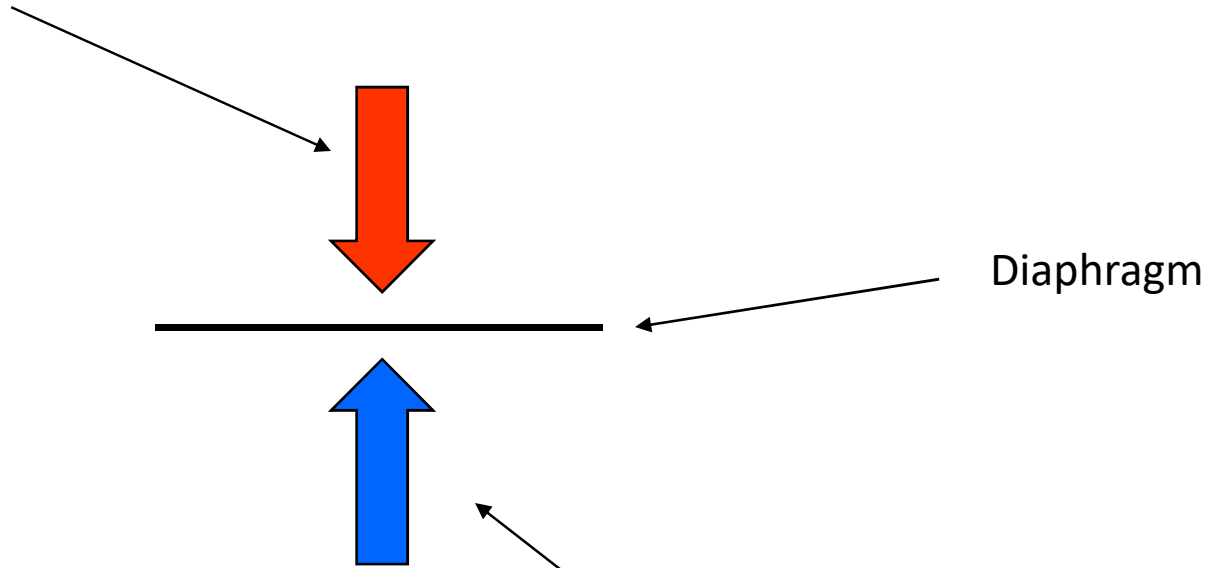

Diaphragm

***Two pressures control
the automatic
expansion valve***

Evaporator pressure
pushes up to close the
valve

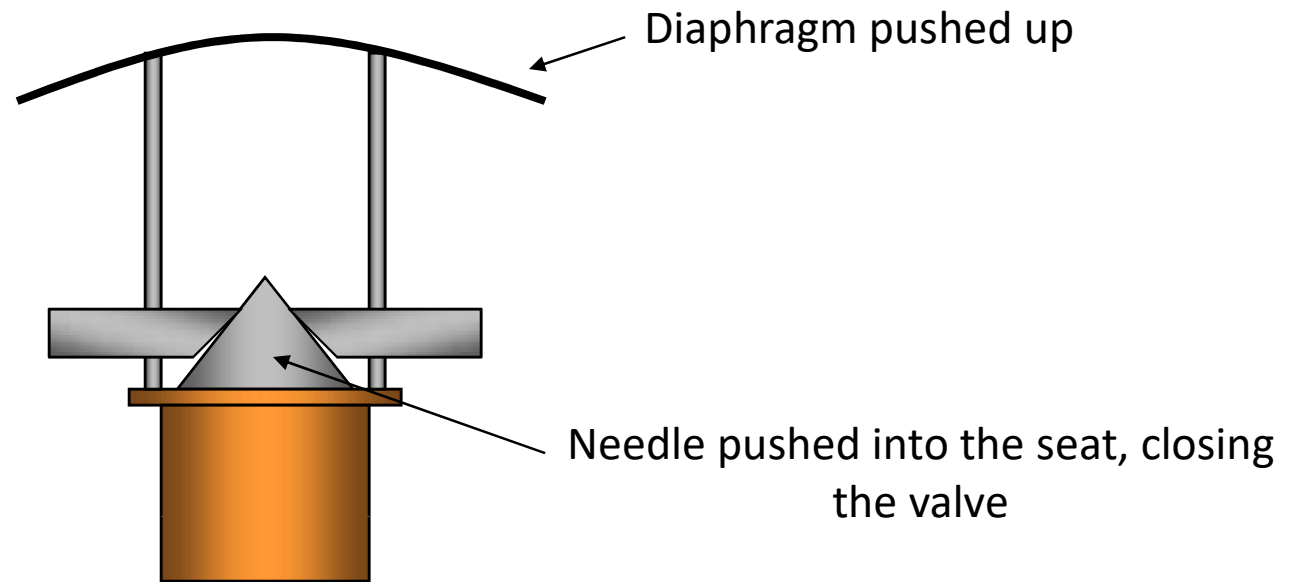

Caused by an increase in evaporator pressure

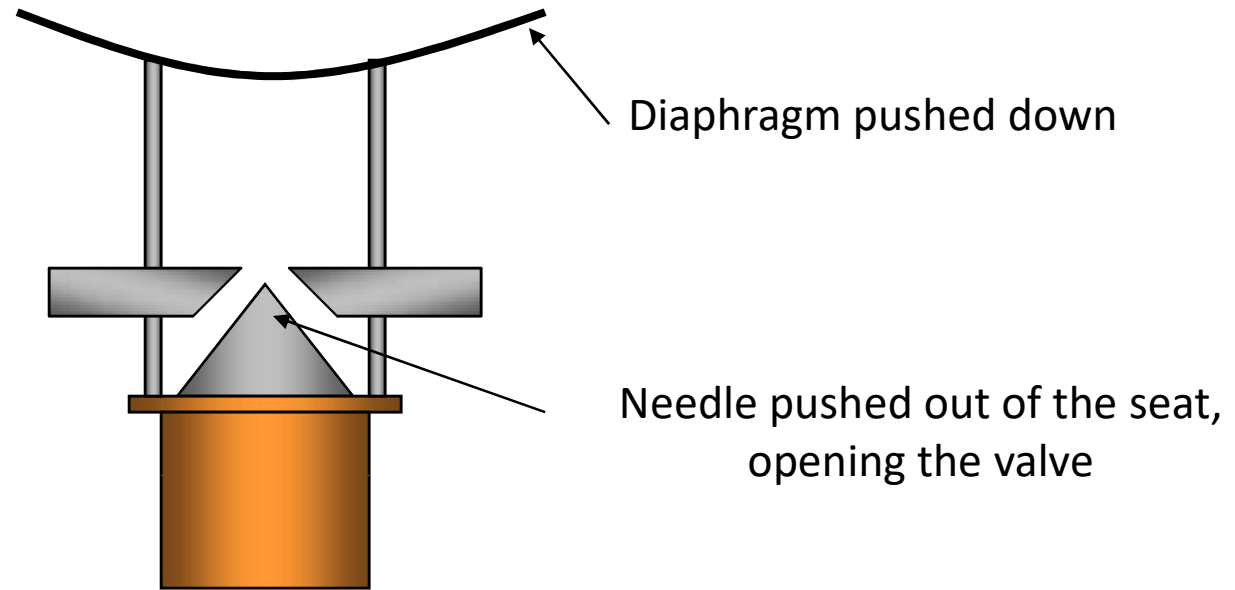

Caused by a decrease in evaporator pressure

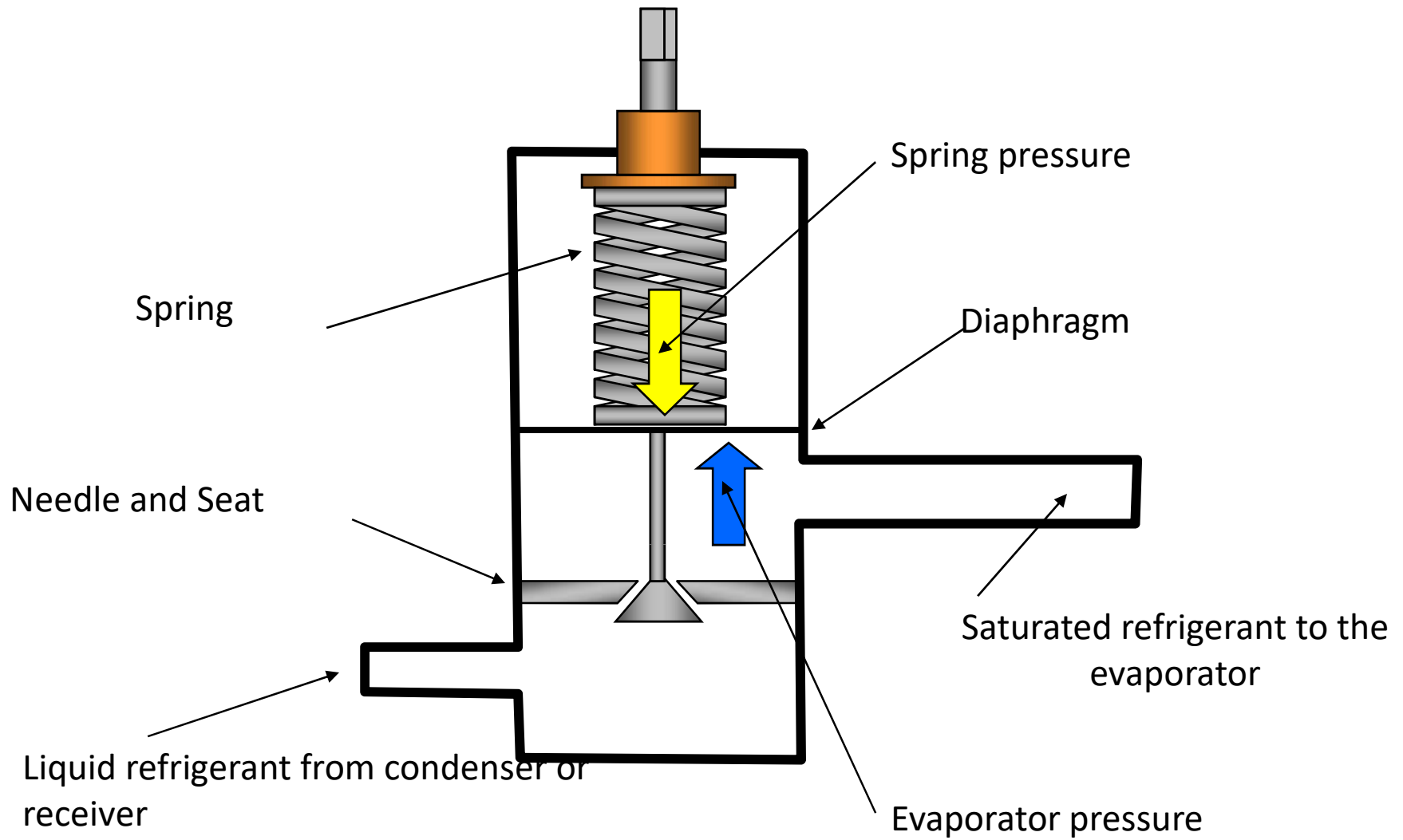

AUTOMATIC EXPANSION VALVE RESPONSE TO LOAD CHANGES

- Responds in reverse to load changes
- If the load increases
 - Refrigerant boils faster in the evaporator
 - The evaporator pressure increases
 - The valve closes
- Used where the load is fairly constant

THE CAPILLARY TUBE METERING DEVICE

- Controls refrigerant flow by the pressure drop across it
- Diameter and length of the tube determine flow at a given pressure
- Does not maintain evaporator pressure or superheat
- Used when the load is relatively constant
- No moving parts to wear out

OPERATING CHARGE FOR THE CAPILLARY TUBE SYSTEM

- Capillary tube systems are critically charged
- All refrigerant in the system circulates at all times when the system is running
- Capillary tube sometimes fastened to the suction line for heat exchange
- Responds very slowly to system load changes

SUMMARY

- Expansion devices meter the correct amount of refrigerant to the evaporator according to system operating conditions
- Common expansion valves include the capillary tube, automatic expansion valve and the thermostatic expansion valve
- The thermostatic expansion valve is designed to maintain constant superheat in the evaporator

SUMMARY cont.

- The automatic expansion valve maintains a constant evaporator pressure
- Two pressure control the AXV: the spring pressure and the evaporator pressure
- The capillary tube is a fixed bore metering device
- The capillary tube meters refrigerant depending on the pressure drop across the tube



How does a domestic refrigerator works ?

Dr. Harmesh Kumar
Deptt. of Mechanical Engineering



Baba Banda Singh Bahadur
Engineering College, Fatehgarh Sahib

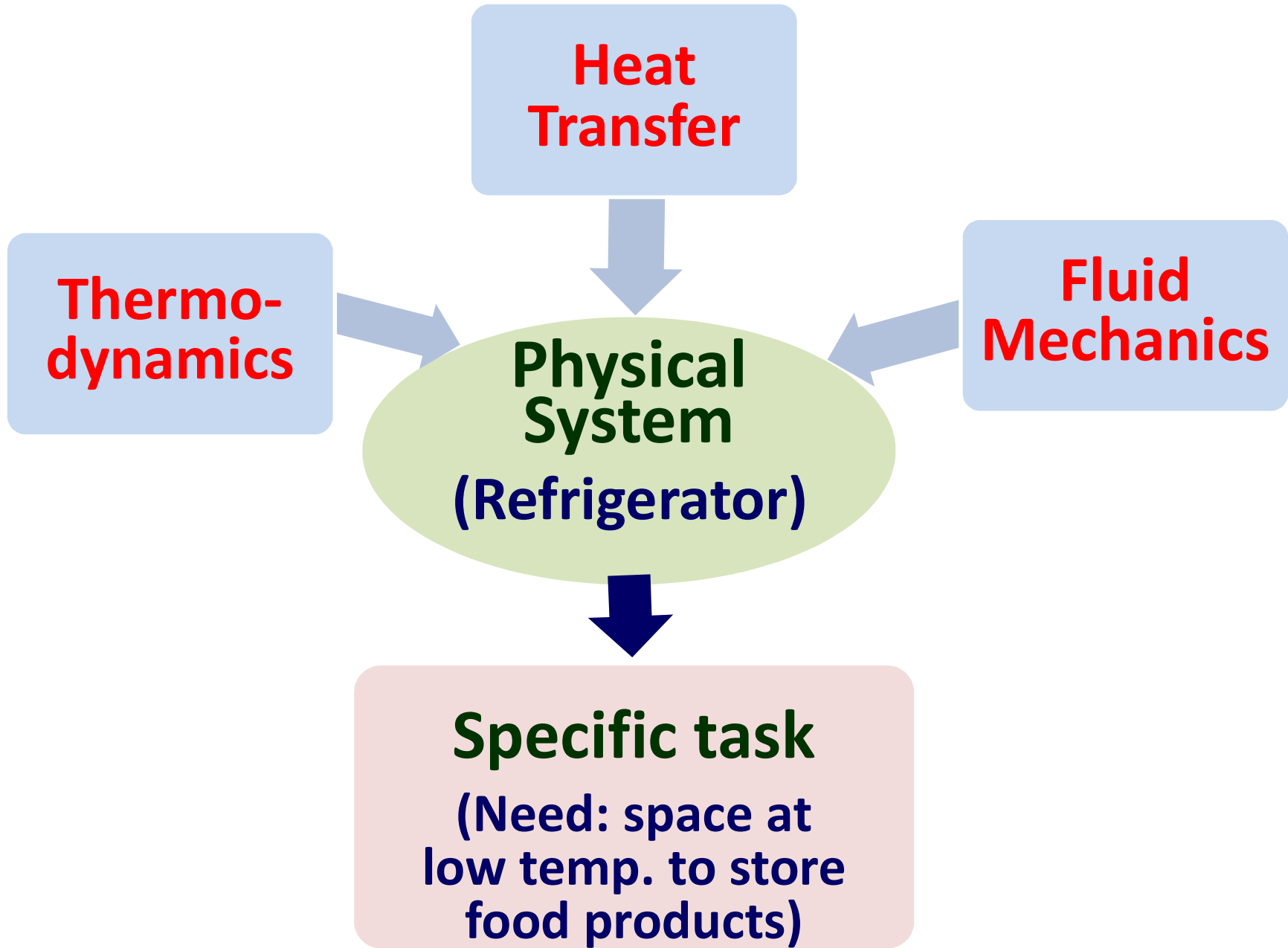

Contents

- Refrigeration
- Specification and Working of Refrigerator
- Units of Refrigeration
- Applications of Refrigeration
- Reasons for the Rapid Growth of Refrigeration Technology

Refrigeration

- “the process of **achieving and maintaining** the temperature of a region/space **below the surrounding temperature**”.



Surrounding
Temp.= 30 °C

Refrigerationcont.

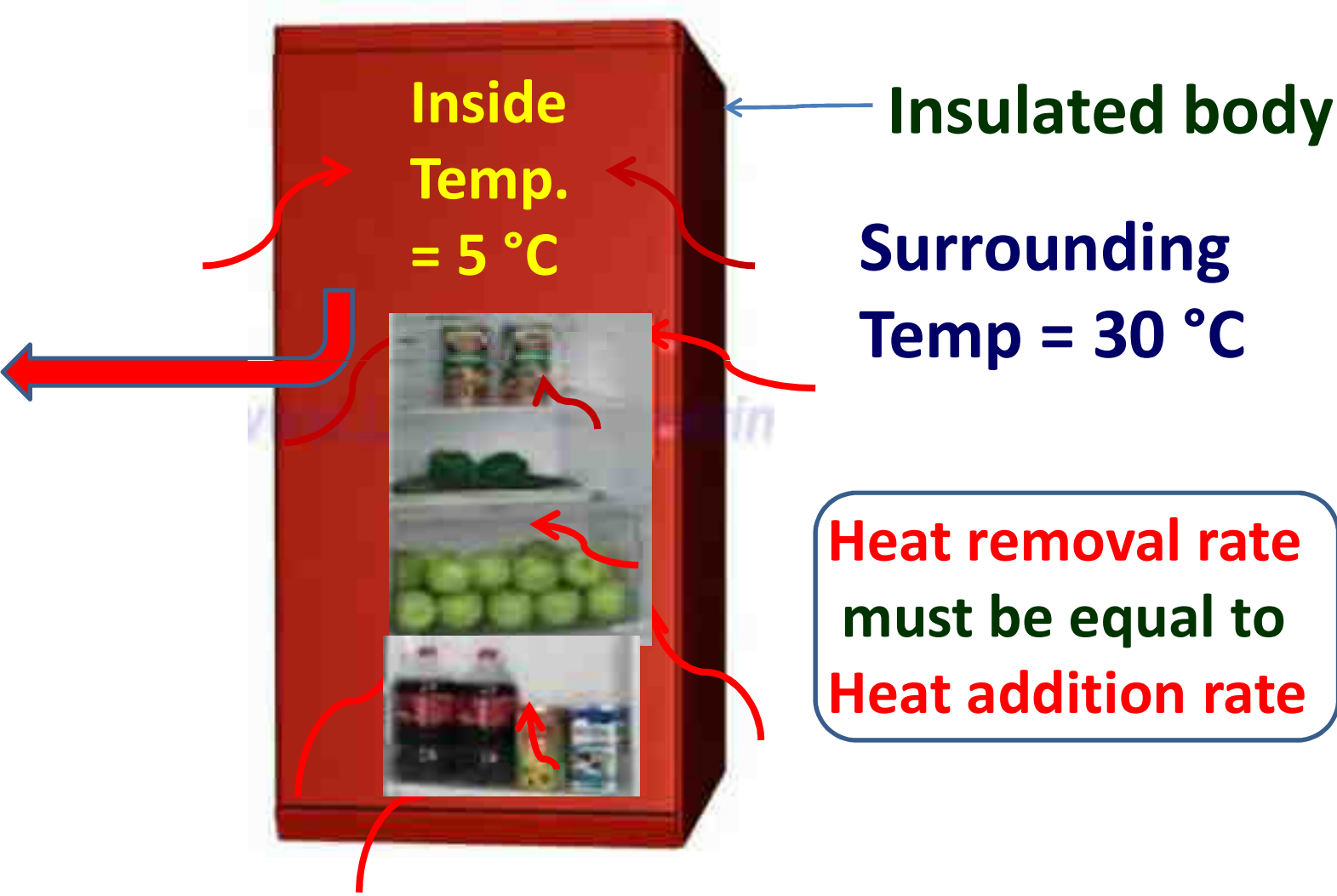

Refrigerator

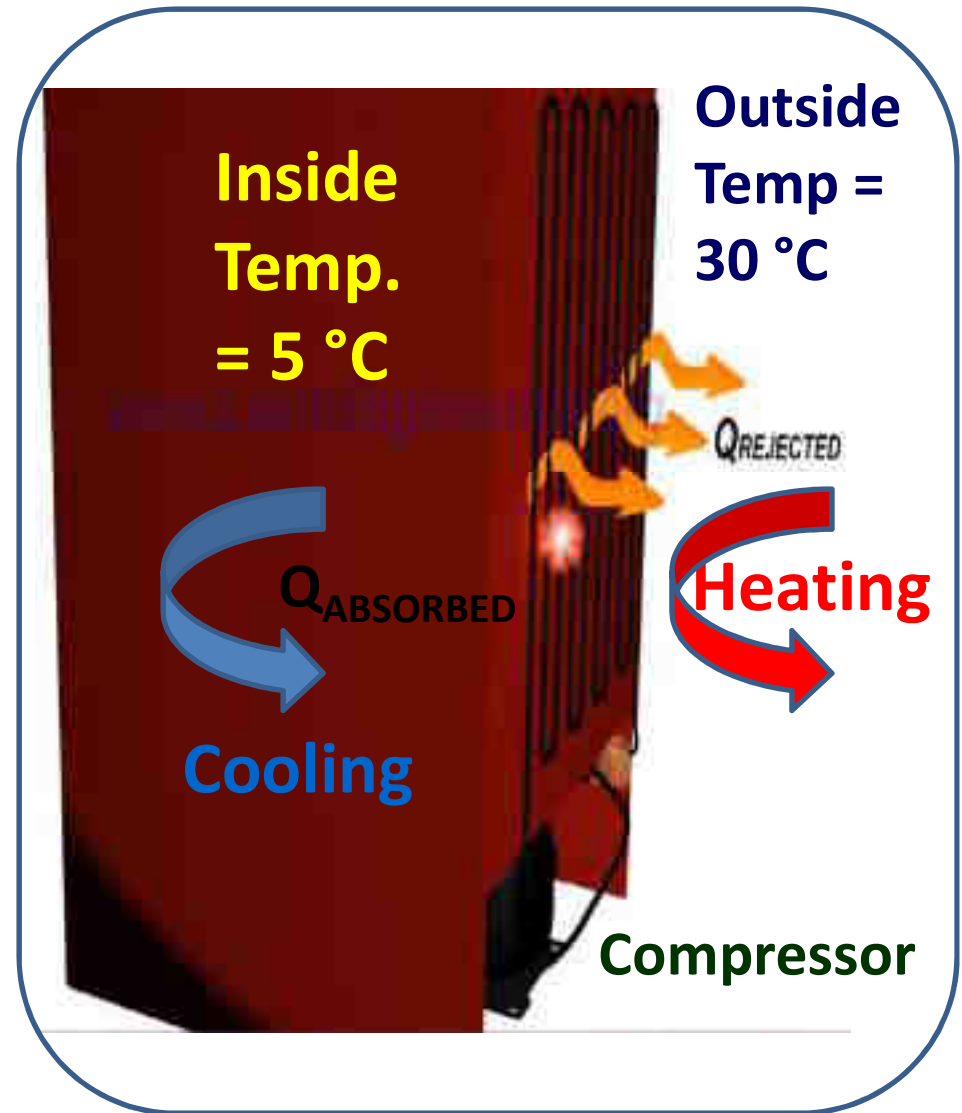
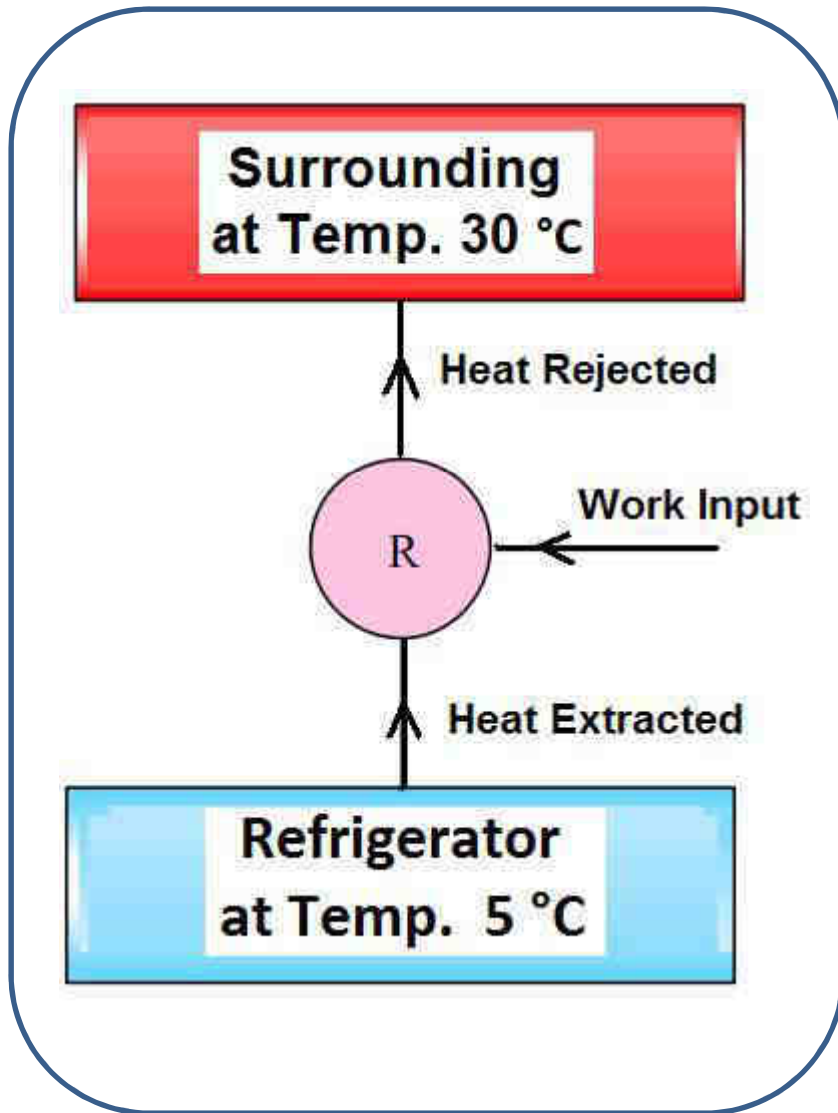

Specifications of Refrigerator

- **Gross Volume**

Measured volume enclosed within a compartment **in liters.**

- **Storage Volume**

When the storage volume is determined, internal fittings like shelves, removable partitions, containers & internal housings are believed to be in place.

Specifications cont.



Understanding Energy Label for Refrigerator

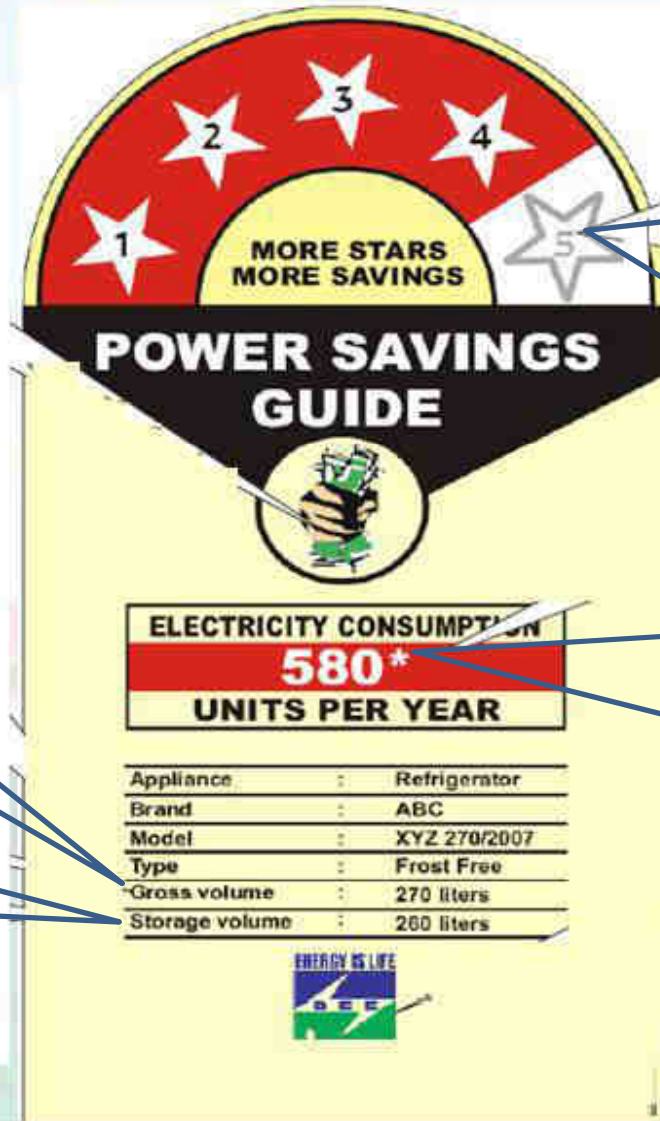

Energy Star Rating Refrigerator: 1 Star is less efficient and 5 Star is more efficient

Annual Energy Consumption (in kWh) under tested conditions

Gross Volume In Liters

Storage Volume In Liters

Working of Domestic Refrigerator

Basic Components of Refrigerator

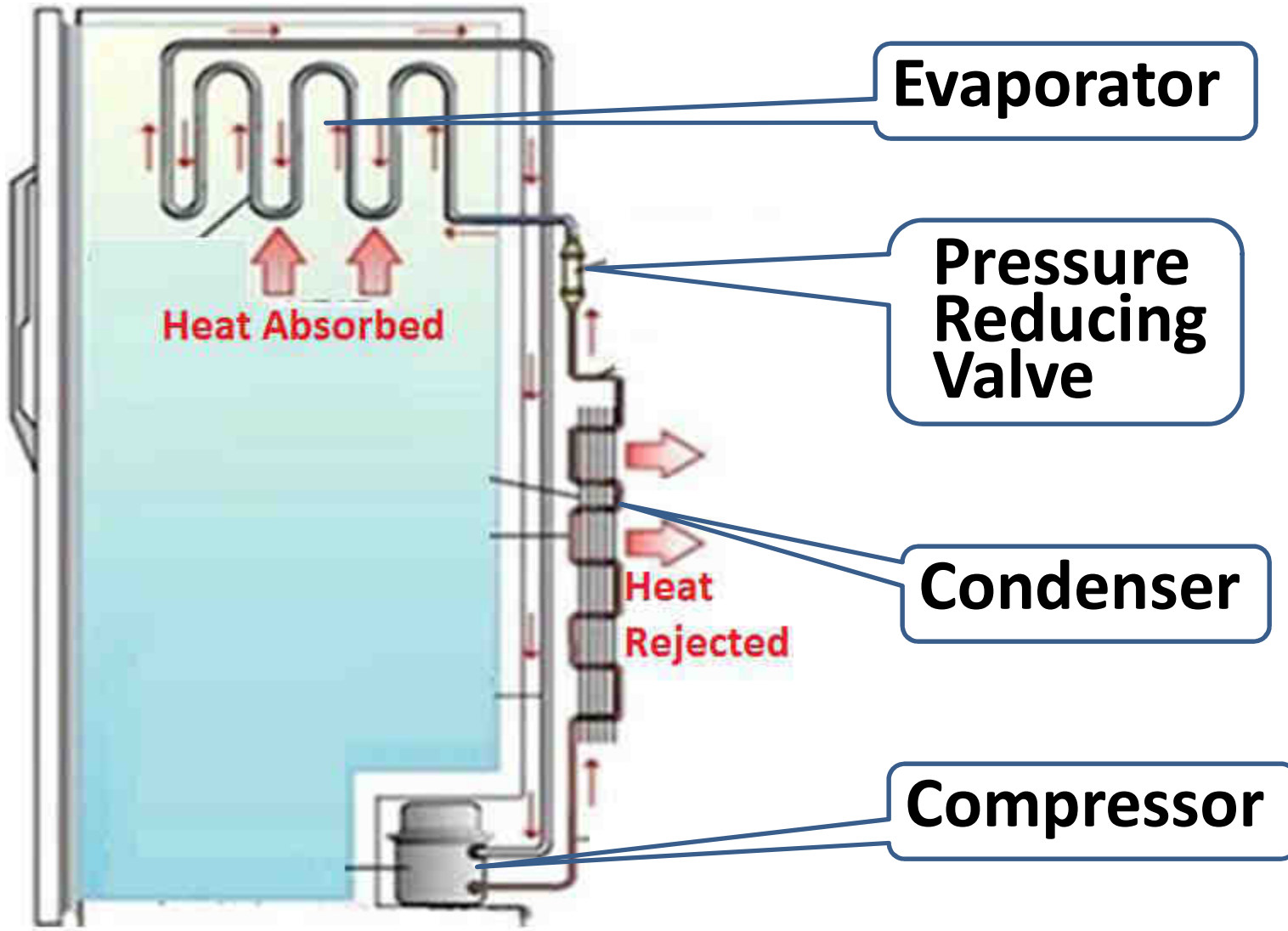

Evaporation

Evaporative Cooling

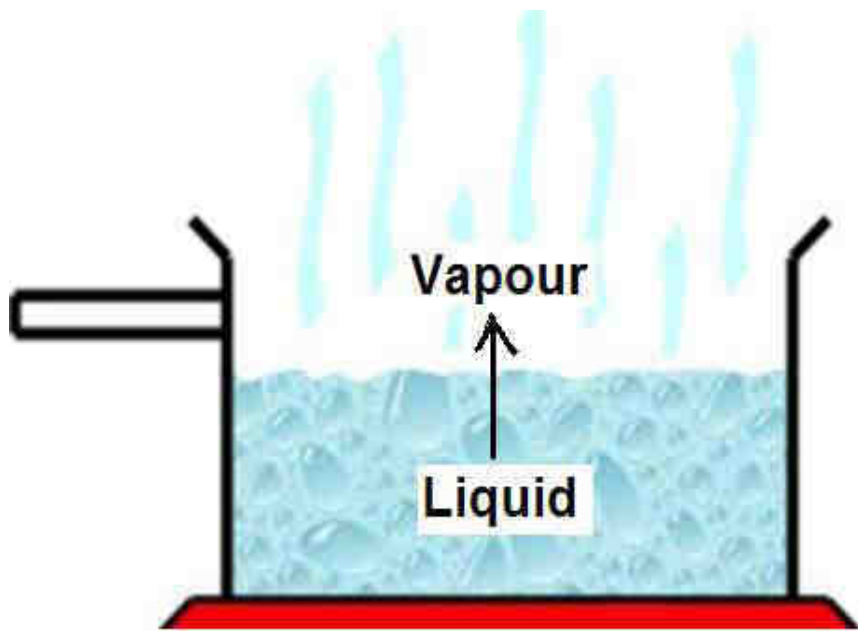

- Absorb heat from surrounding
- Endothermic phase transformation

Examples

- Earthen pot
- Desert Cooler

Evaporation cont.

What is the boiling (evaporation) temperature of water?)

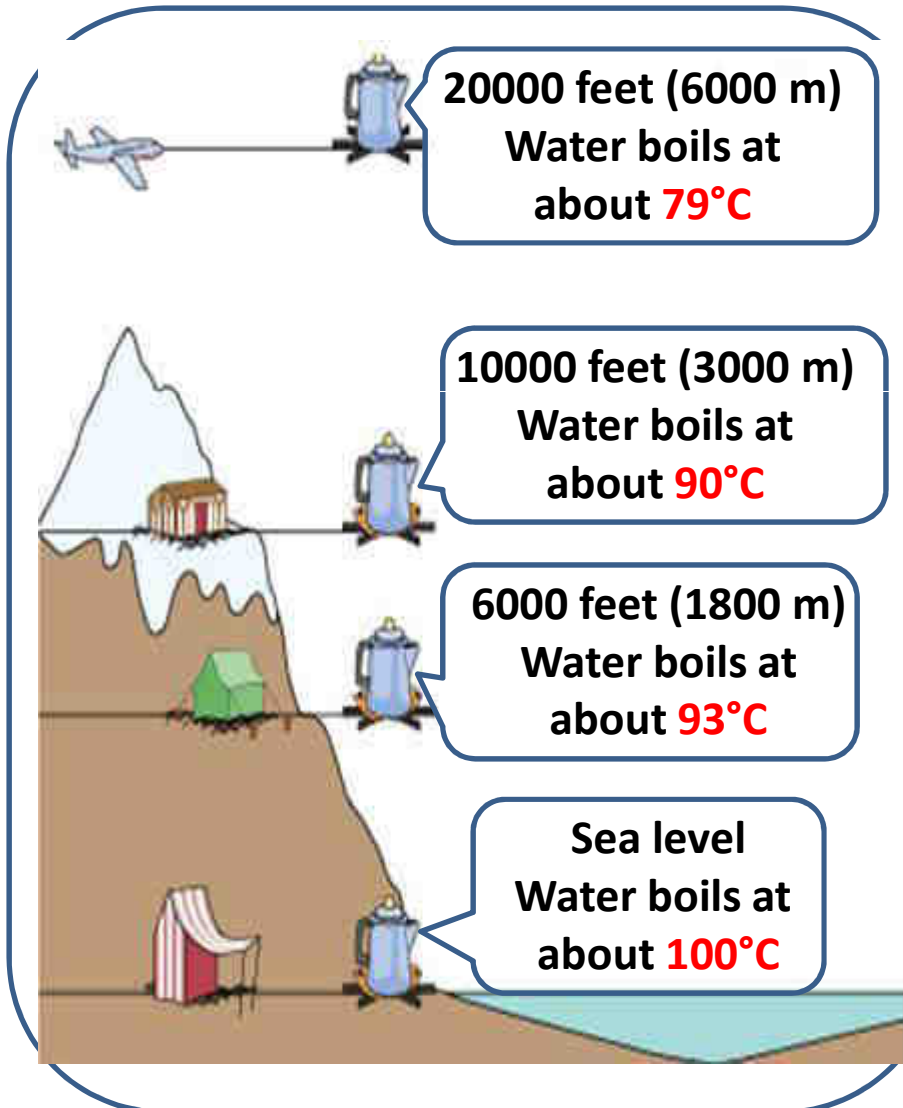

Rate of evaporation

- Pressure above the liquid surface

Low Pressure → Favour Evaporation

Type of fluid

- At Atmospheric Pressure
 - Water 100 °C
 - Petrol at room temp.
 - Ammonia at -35 °C

1. Evaporator

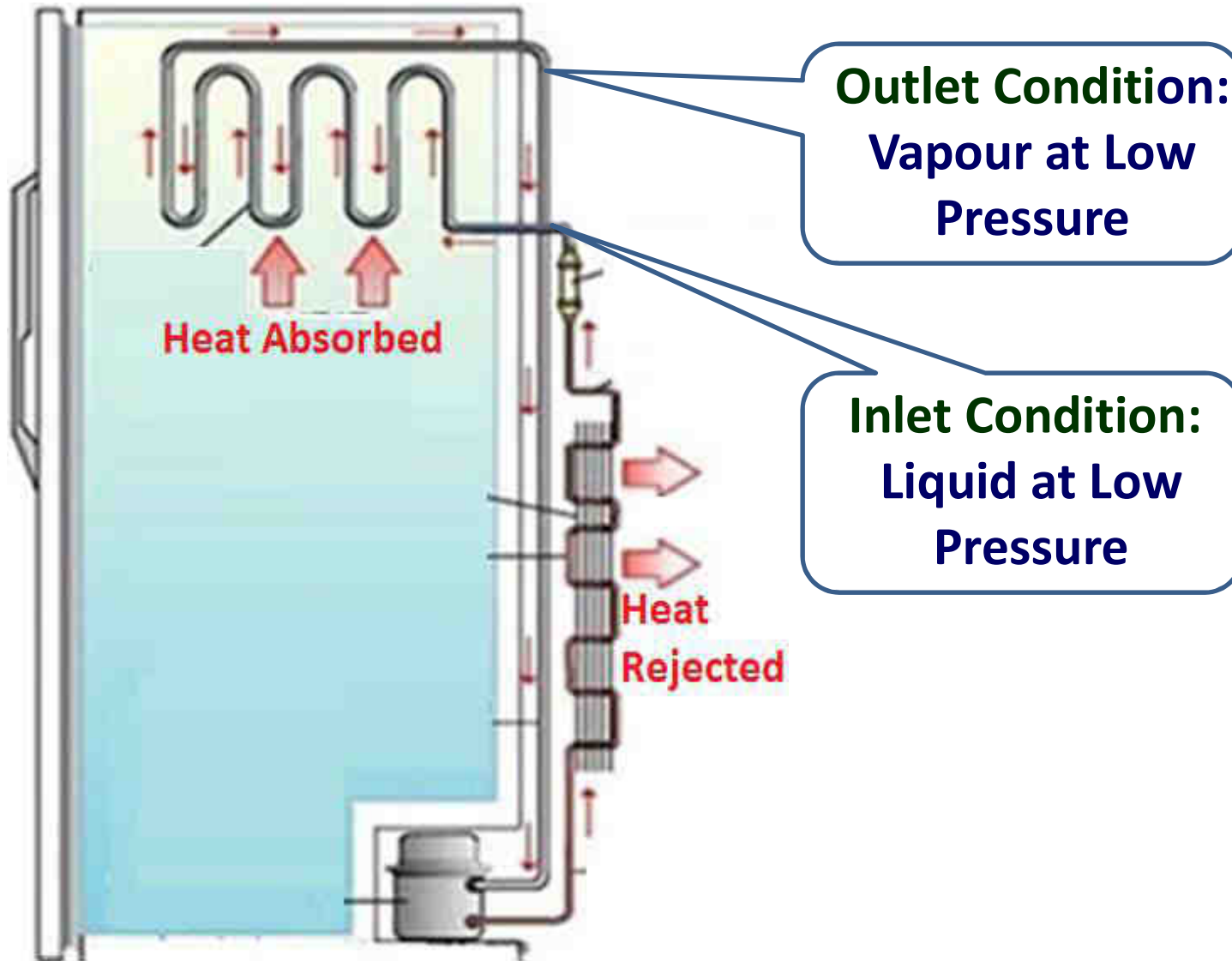

For Continues Cooling

Low Pressure Vapours



Low Pressure Liquid

Condensation

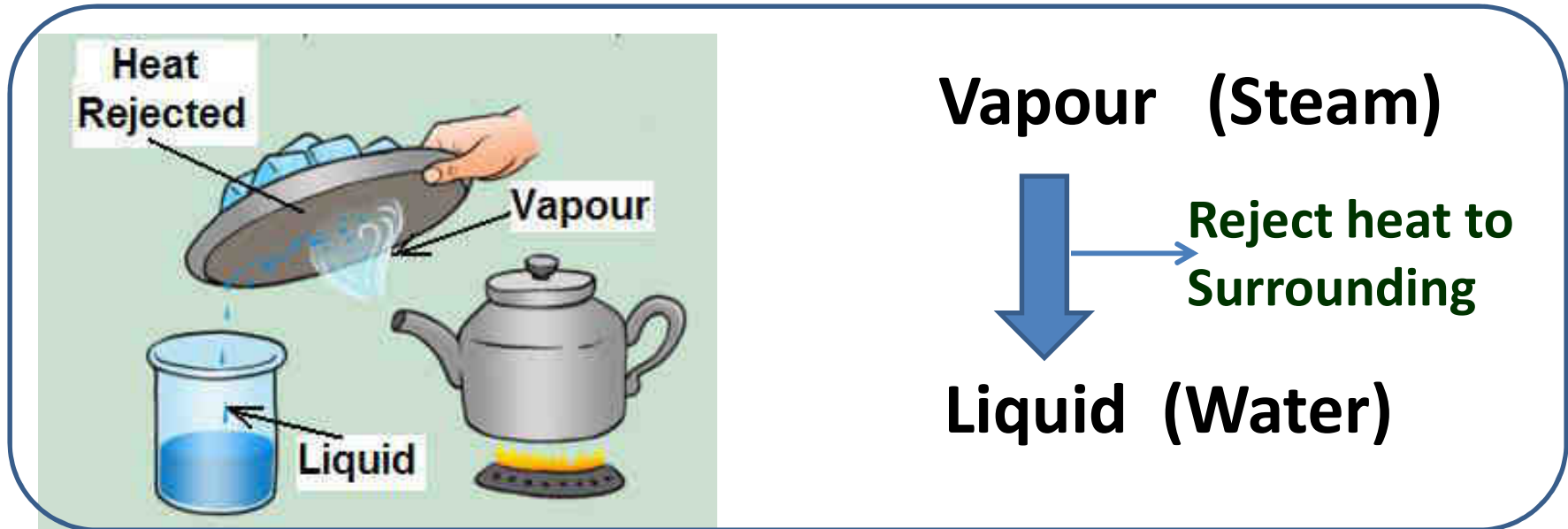

2. Compressor

- Raise Pressure
- Maintain Flow

Inlet condition =
Low pressure
Vapour Refrigerant
(0.6 bar, -20°C)

Outlet condition =
High pressure
Vapour Refrigerant
(8 bar, 90°C)

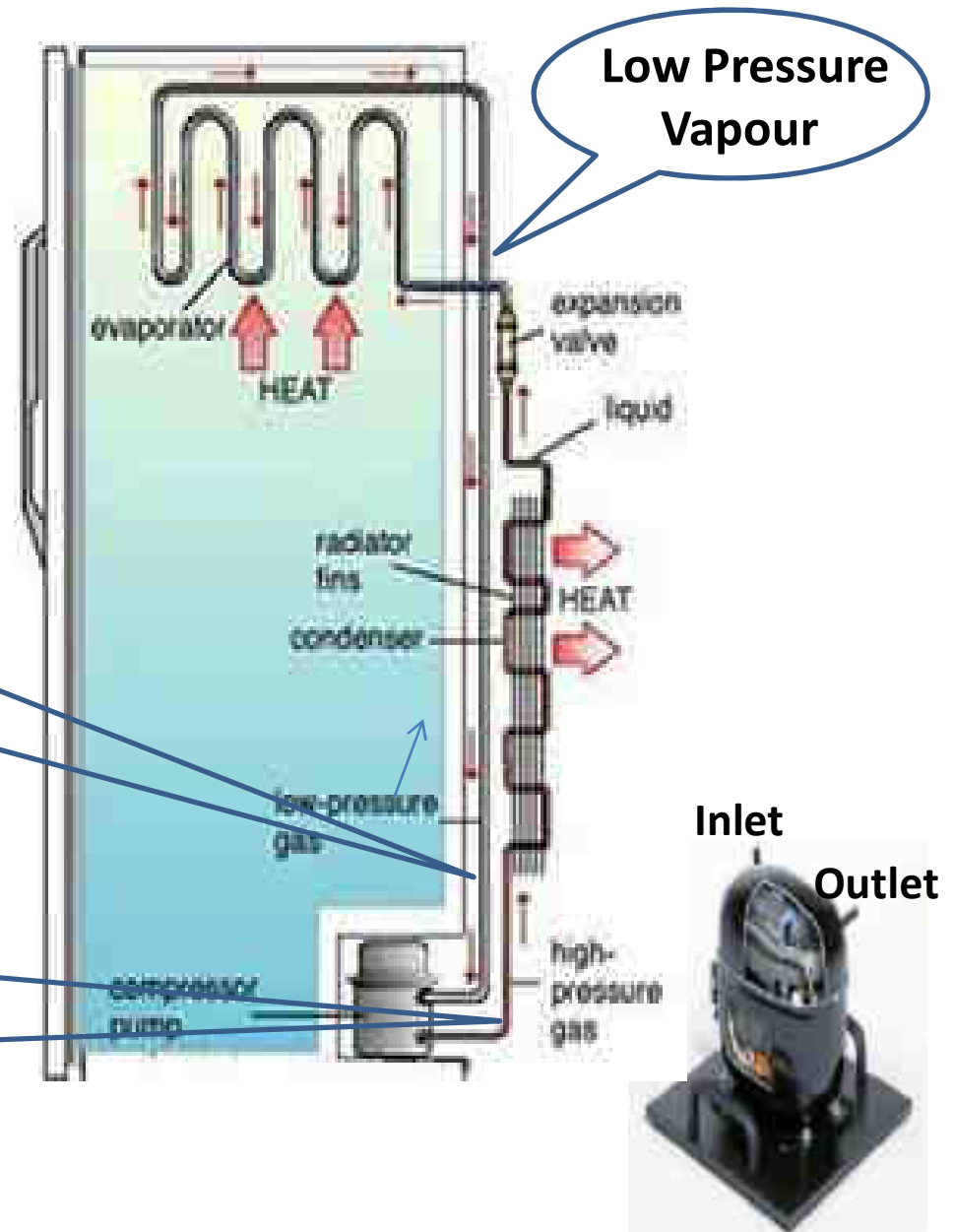

3. Condenser

- Reject heat to surrounding
Vapour → **Liquid**

Refrigerant outlet **8bar**
Liquid at high pressure

Refrigerant inlet **8bar**
Vapour at high pressure

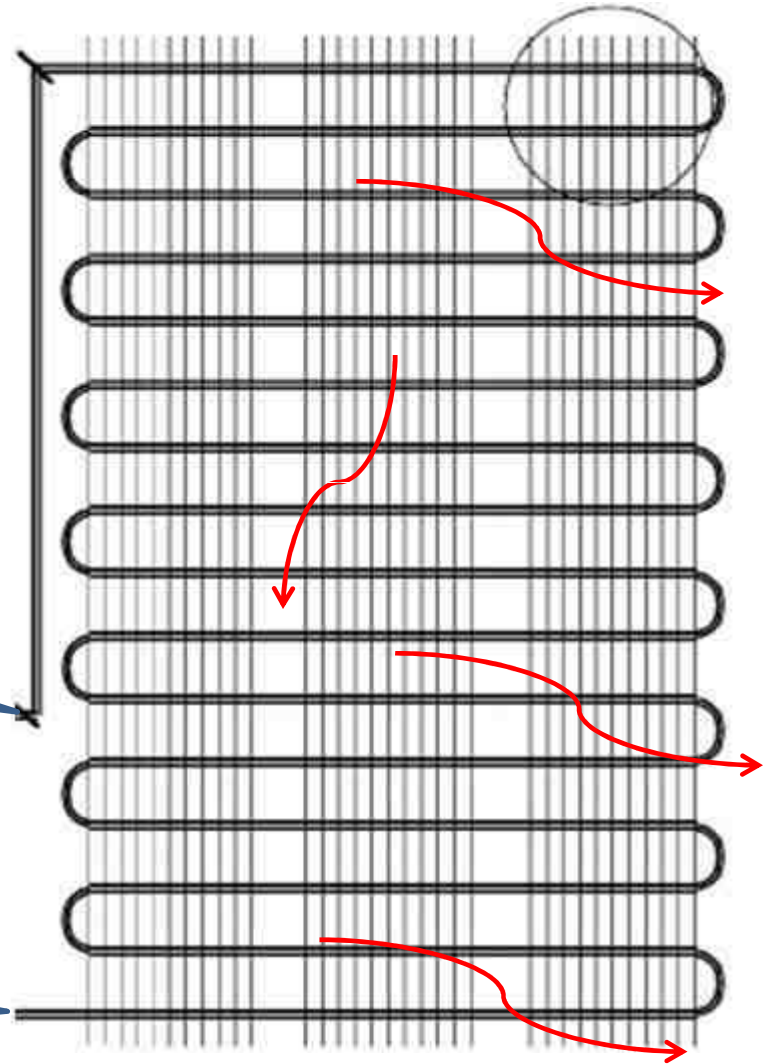

4. Pressure Reducing Valve

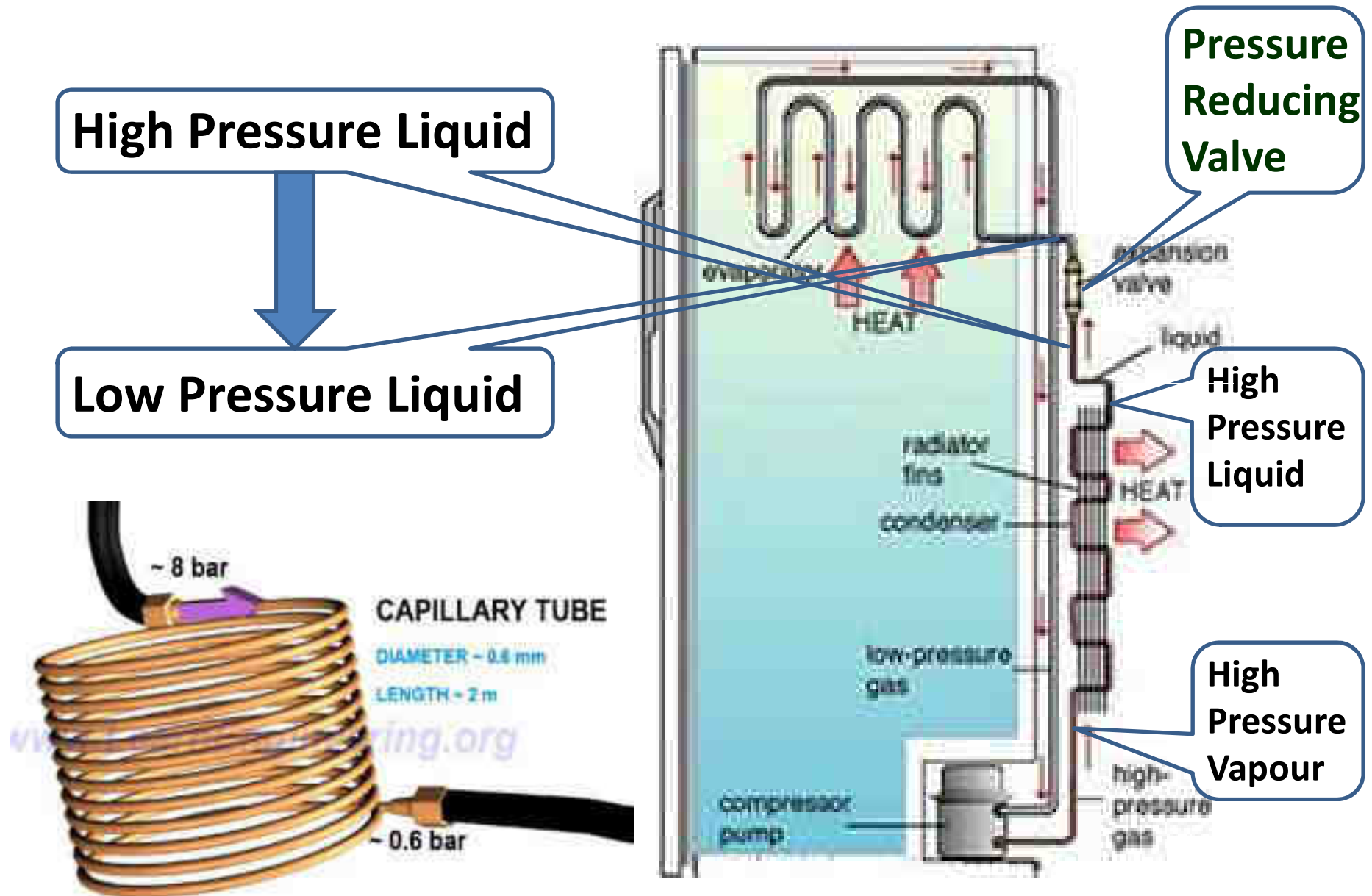

Working of Refrigerator

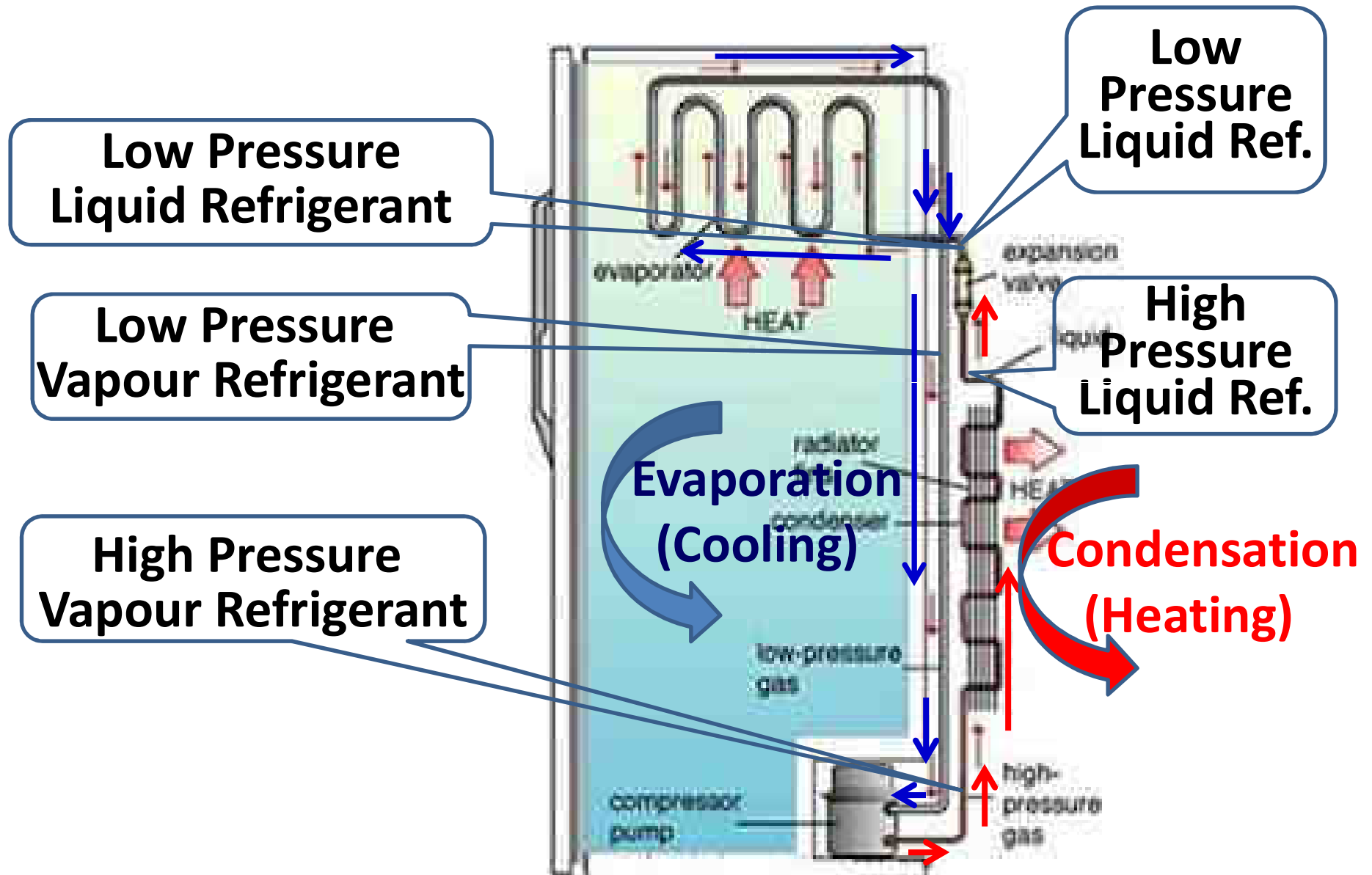

Performance of Refrigerator

$$\text{Performance} = \frac{\text{Output}}{\text{Input}}$$

$$\text{Performance} = \frac{\text{Cooling Effect}}{\text{Work Input (Compressor)}}$$

RAC Lab Equipment's Ice Plant Test Rig



Air-Conditioner Test Rig



Water Cooler Test Rig



Analysis of Refrigeration Cycle



THANKS!
THANKS!

Numericals Based on Vapour Compression Cycle

Pressure Enthalpy Graph

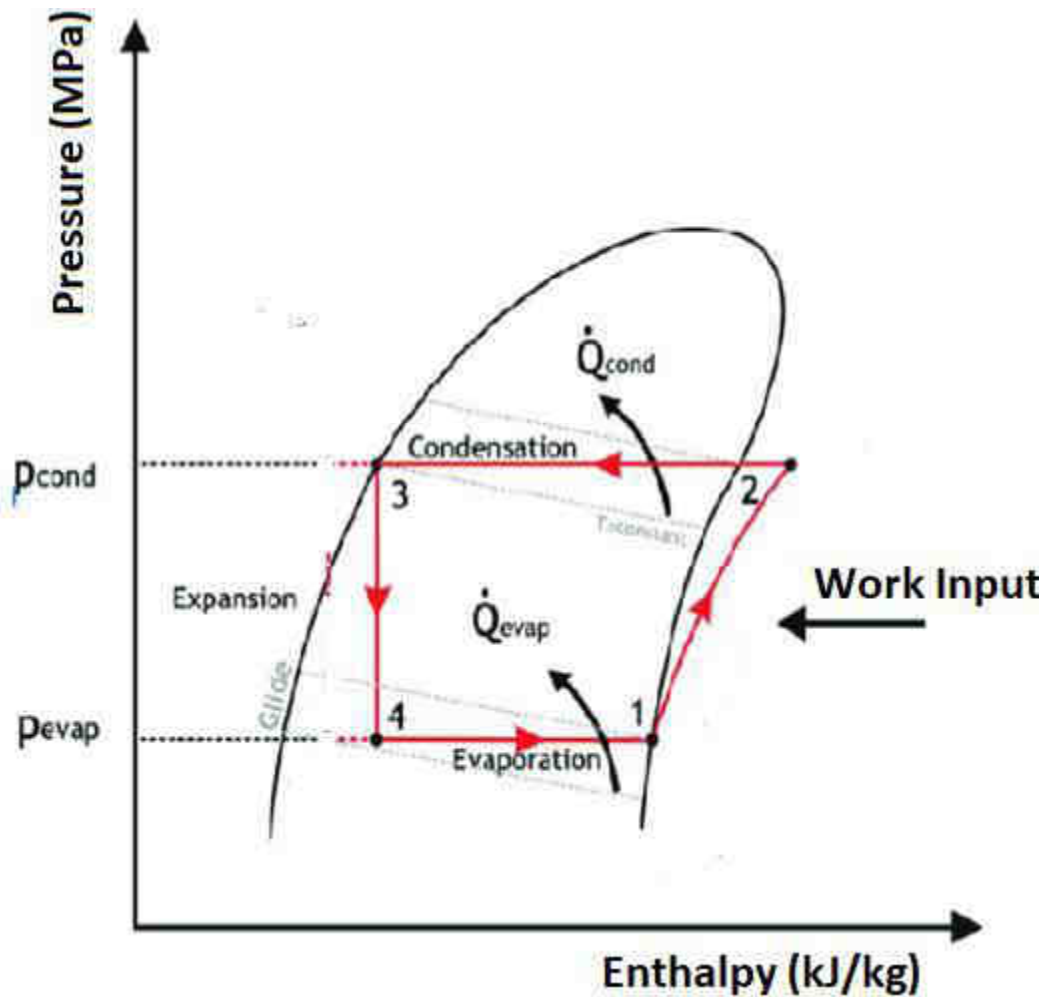

- **1-2** Isentropic compression in compressor
- **2-3** constant pressure heat rejection in condenser
- **3-4** isenthalpic process in expansion device
- **4-1** constant pressure heat absorption in evaporator

Question.1

- **The boiling point of a liquid decreases with the**
 - (a) Decrease of pressure
 - (b) Increase of pressure
 - (c) Increase of pressure and volume
 - (d) None

Ans: **(a)**

Question.2

- **During a refrigeration cycle, heat is rejected by the refrigerant in a**
 - a) Compressor
 - b) Condenser
 - c) Evaporator
 - d) Expansion valve

Question.3

- **For an expansion device, which of the following is true?**
 - a) it increases the pressure of refrigerant
 - b) it decreases the pressure of refrigerant
 - c) it changes the phase of refrigerant from vapour to liquid
 - d) it changes the phase of refrigerant from liquid to vapour

Question.4

A standard vapour compression refrigeration cycle consists of the following 4 thermodynamic processes in sequence:

- (a)** Isothermal expansion, isentropic compression, isothermal compression and isentropic expansion
- (b)** Constant pressure heat addition, isentropic compression, constant pressure heat rejection and isenthalpic expansion
- (c)** Constant pressure heat addition, isentropic compression, constant pressure heat rejection and isentropic expansion
- (d)** Isothermal expansion, constant pressure heat addition, isothermal compression and constant pressure heat rejection

Ans. (b)

Question.5

In a vapour compression cycle, the refrigerant, immediately after expansion valve (or throttling) is:

- (a) Saturated liquid
- (b) Subcooled liquid
- (c) Dry vapour
- (d) Wet vapour

Ans. (d)

P-h and T-S Graphs

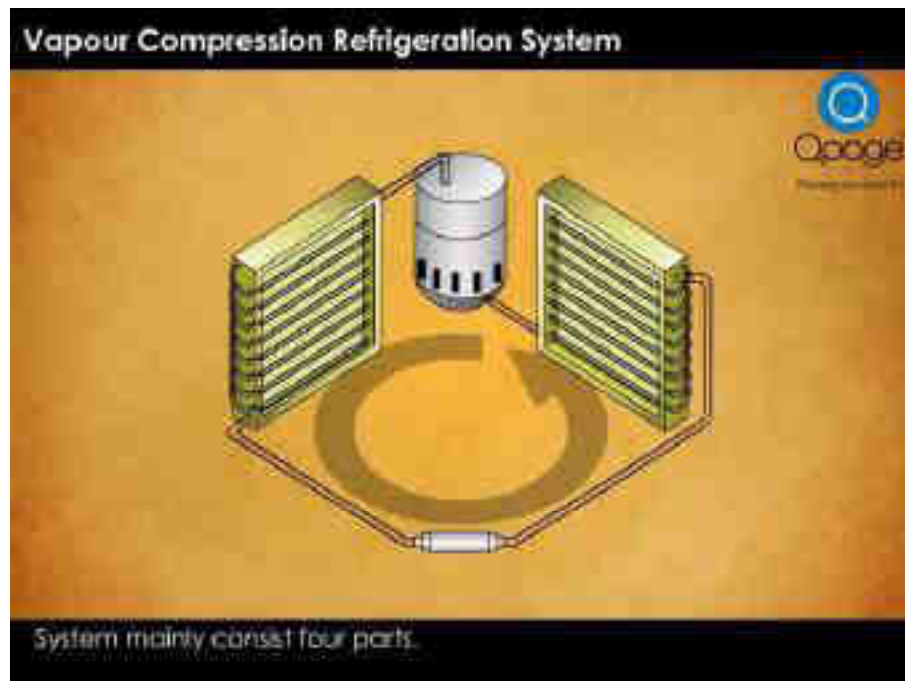

- 1-2** Isentropic compression in compressor
- 2-3** Isobaric heat rejection in condenser
- 3-4** Throttling or (isenthalpic process) in expansion device
- 4-1** Isobaric heat absorption in evaporator

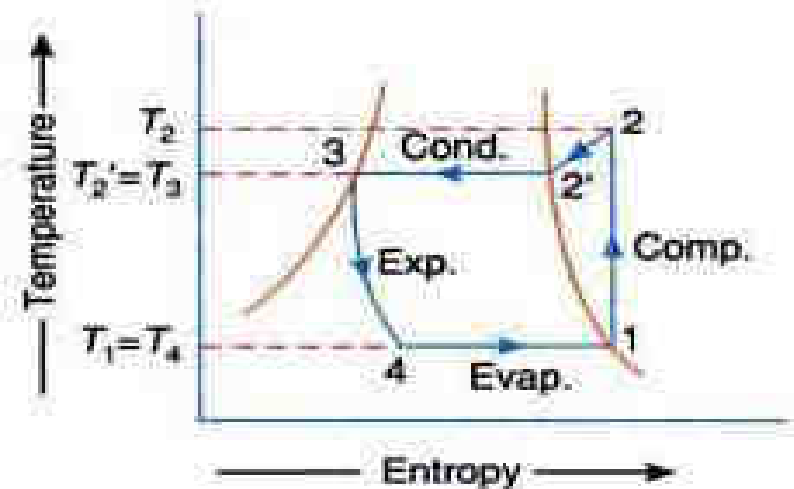
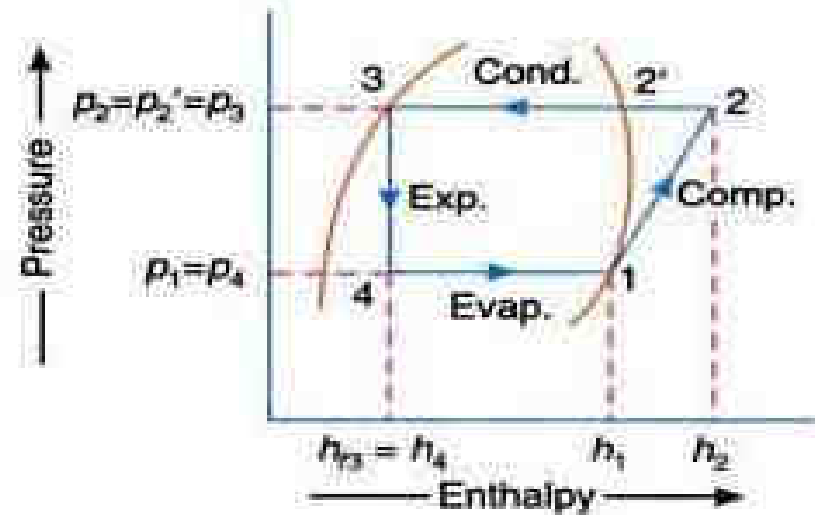

Temperature- Entropy Graph

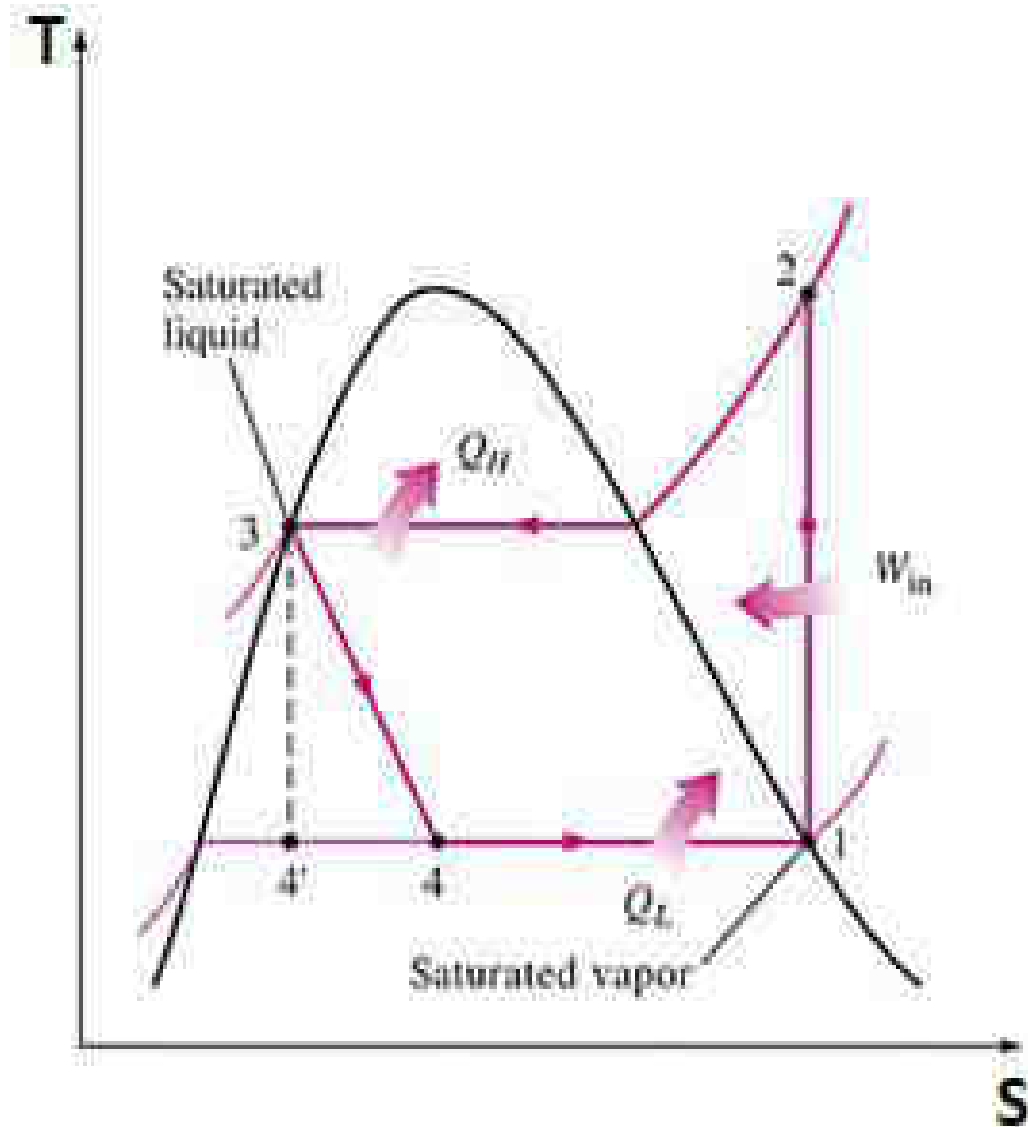

- **1-2** Isentropic compression in compressor
- **2-3** Isobaric heat rejection in condenser
- **3-4** Throttling in expansion device
- **4-1** Isobaric heat absorption in evaporator

Analysis of Vapor-Compression Cycle

- ▶ Applying mass and energy rate balances

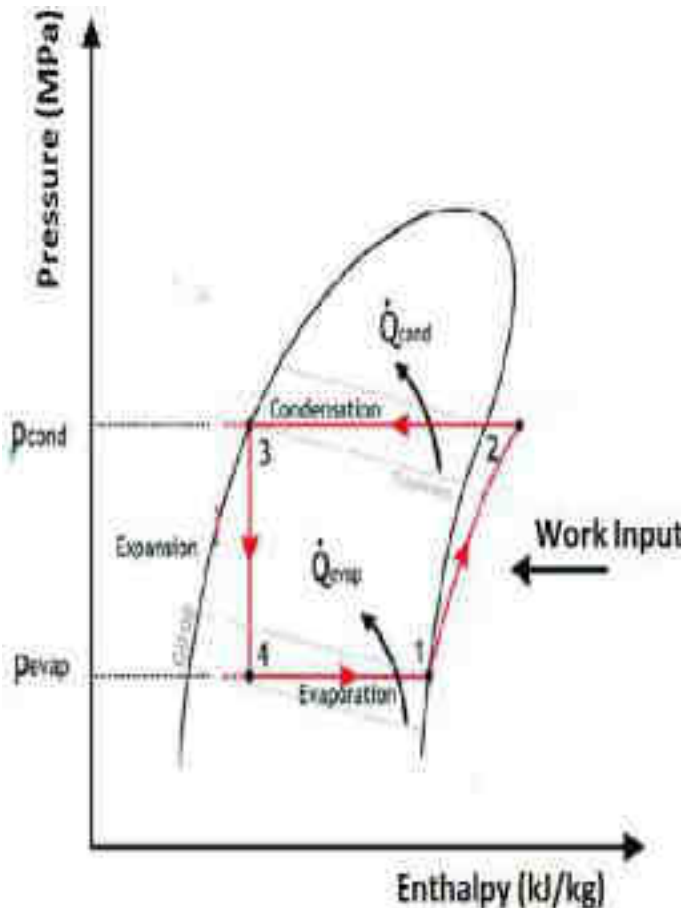

Evaporator

Isobaric heat absorption

Refrigerant effect = $h_1 - h_4$ kJ/kg

Refrigerating capacity = $m_r(h_1 - h_4)$ kJ/min

m_r - mass flow rate of refrigerant kg/min

Ref. capacity (in kW) = $m_r(h_1 - h_4)/60$ kW

Alternative units:

Ref. capacity (in TR) = $m_r(h_1 - h_4)/210$ TR

1 TR = 210 kJ/min

Analysis

cont...

Compressor

(Assuming isentropic compression)

Compressor work input = $h_2 - h_1$ kJ/kg

Rate of work input = $m (h_2 - h_1)$ kJ/min

Power = $m (h_2 - h_1)/60$ kJ/sec (or kW)

Condenser

(Assuming Isobaric heat rejection)

Heat rejection = $h_2 - h_3$ kJ/kg

Rate of heat rejection = $m (h_2 - h_3)$ kJ/min

Rate of heat rejection = $m (h_2 - h_3)/60$ kW

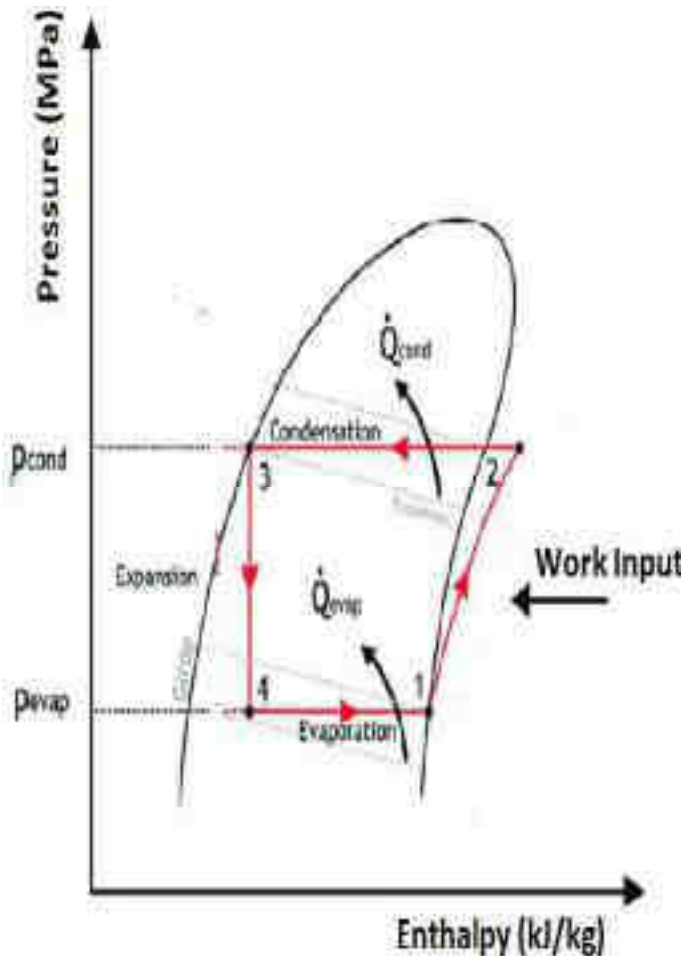

Analysis

cont...

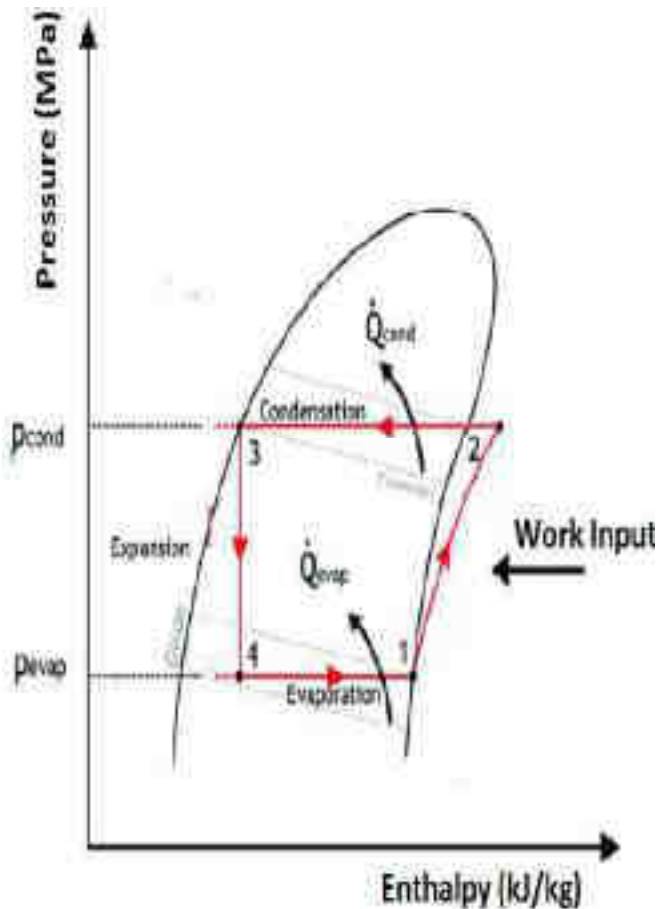

Expansion valve/ Capillary tube
(Assuming isenthalpic process)

$$h_3 = h_4$$

Coefficient of Performance (COP)

$$\text{COP} = \frac{\text{Refrigeration Effect/kg}}{\text{Work Input/kg}} = \frac{h_1 - h_4}{h_2 - h_1}$$

Q.1

In an ideal vapour compression refrigeration cycle, the **specific enthalpy** of refrigerant (in kJ/kg) at the following stages is given as:

Inlet of condenser: 283;

Exit of condenser: 116;

Exit of evaporator: 116;

The COP of the cycle is

(a) 2.27

(b) 2.75

(c) 3.27

(d) 3.75

Solution:

Given data

$$h_2 = 283 \text{ kJ/kg}$$

$$h_3 = 116 \text{ kJ/kg} = h_4$$

$$h_1 = 232 \text{ kJ/kg}$$

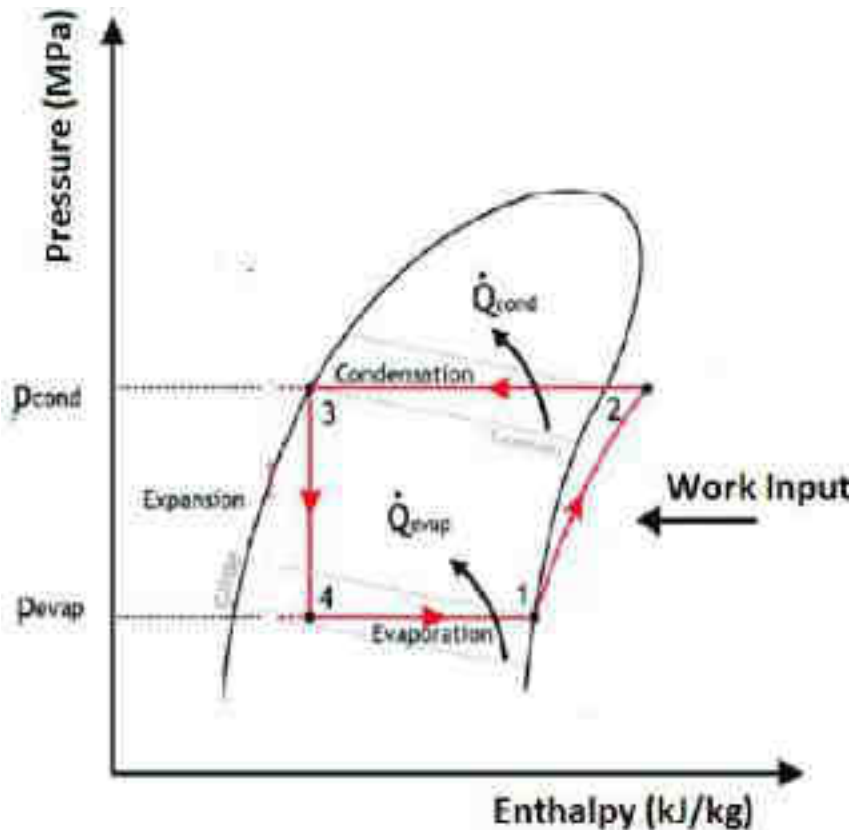

$$\text{COP} = \text{R.E./Work}_{\text{input}}$$

$$\begin{aligned} \text{RE} &= h_1 - h_4 \\ &= 232 - 116 = 116 \text{ kJ/kg} \end{aligned}$$

$$\begin{aligned} w_{1-2} &= h_2 - h_1 \\ &= 283 - 232 = 51 \text{ kJ/kg} \end{aligned}$$

$$\text{COP} = 116/51 = 2.27$$

Q2.

Refrigerant vapour enters into the compressor of standard vapour compression cycle at $-10\text{ }^{\circ}\text{C}$ ($h = 402\text{ kJ/kg}$) and leaves the compression at $50\text{ }^{\circ}\text{C}$ ($h = 432\text{ kJ/kg}$). It leaves the condenser at $30\text{ }^{\circ}\text{C}$ ($h = 237\text{ kJ/kg}$). The COP of the cycle is

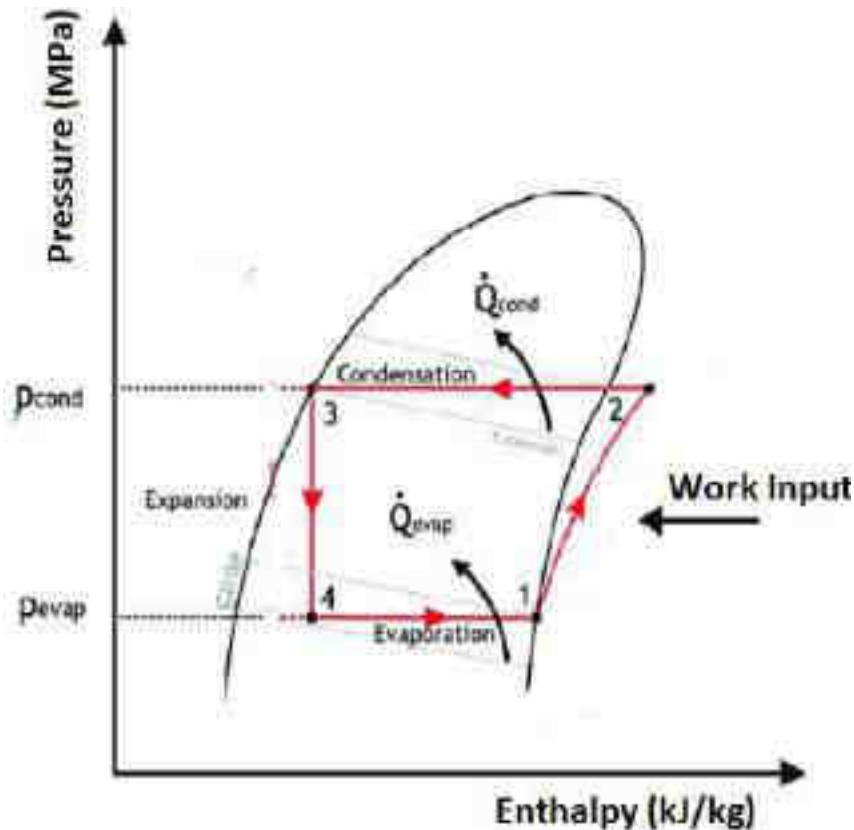

- **Solution**

Given data

$$h_1 = 402 \text{ kJ/kg}$$

$$h_2 = 432 \text{ kJ/kg} = h_4$$

$$h_3 = h_4 = 237 \text{ kJ/kg}$$

$$\text{COP} = \text{RE} / W_{\text{input}}$$

$$\text{RE} = h_1 - h_4$$

$$= 402 - 237 = 165 \text{ kJ/kg}$$

$$W_{1-2} = h_2 - h_1$$

$$= 432 - 402 = 30 \text{ kJ/kg}$$

$$\text{COP} = 165 / 30 = 5.5$$

Q3.

A refrigerator uses **R-134a** its refrigerant and operates on an **ideal vapour compression refrigeration cycle** between **0.14 MPa** and **0.8 MPa**, If the mass flow rate of refrigerant is **0.05kg/s**, the **rate of heat rejection** to the environment in kW, Given data:

saturated vapour

At $P=0.14$ MPa, $h=236.04$ kJ/kg ,

superheated vapour

At $P=0.8$ MPa, $h=272.05$ kJ/kg

saturated liquid

At $P=0.8$ MPa, $h=93.42$ kJ/kg

a) 8.01

b) 8.93

c) 9.72

d) 10.34

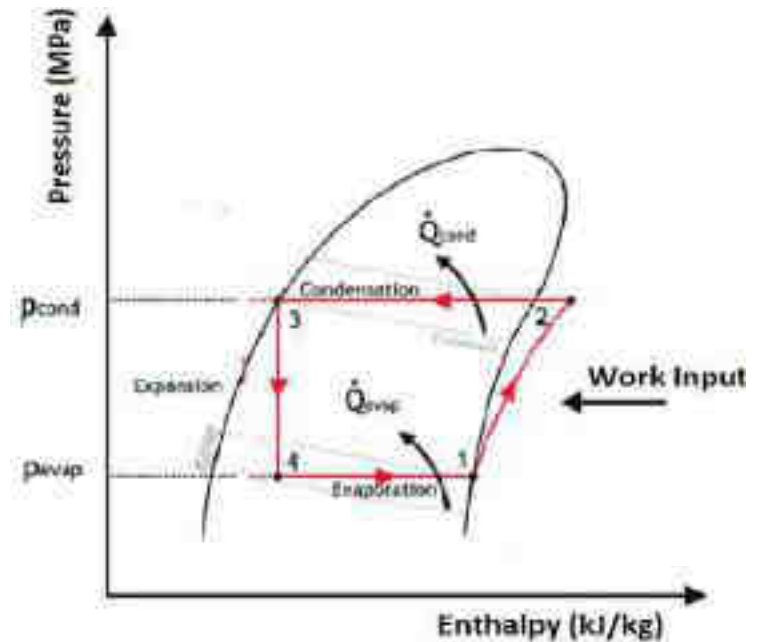

Solution

$$h_1 = 236.04 \text{ kJ/kg}$$

$$h_2 = 272.05 \text{ kJ/kg}$$

$$h_3 = 93.42 \text{ kJ/kg}$$

$$h_4 = h_3$$

$$\text{Heat Rejection} = m (h_2 - h_3)$$

$$= 0.05 (272.05 - 93.42)$$

$$= \mathbf{8.93 \text{ kW}}$$

Q.4

The values of enthalpy at the beginning of compression, at the end of compression and at the end of condensation are 185 kJ/kg, 210 kJ/kg and 85 kJ/kg respectively. What is the value of the **COP** of the vapour compression refrigeration system?

a) 0.25

b) 5.4

c) 4

d) 1.35

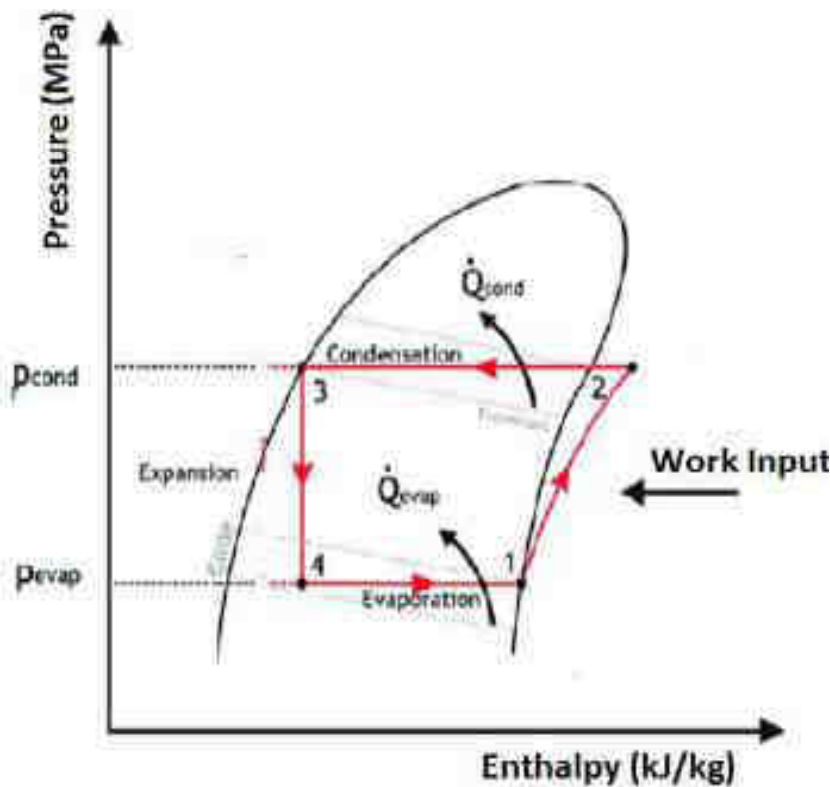

Solution

$$h_1 = 185 \text{ kJ/kg}$$

$$h_2 = 210 \text{ kJ/kg}$$

$$h_3 = 85 \text{ kJ/kg}$$

$$h_4 = h_3$$

$$COP = \frac{(h_1 - h_4)}{(h_2 - h_1)} = \frac{(185 - 85)}{(210 - 185)} = \frac{100}{25} = 4$$

$$\mathbf{COP = 4}$$

Q.5

In a vapour compression refrigeration plant, the refrigerant leaves the **evaporator at 195 kJ/kg** and the **condenser at 65 kJ/kg**. For **1 kg/s** of refrigerant, what is the refrigeration effect?

- (a) 70 KW (b) 100 KW (c) 130 KW (d) 160 KW

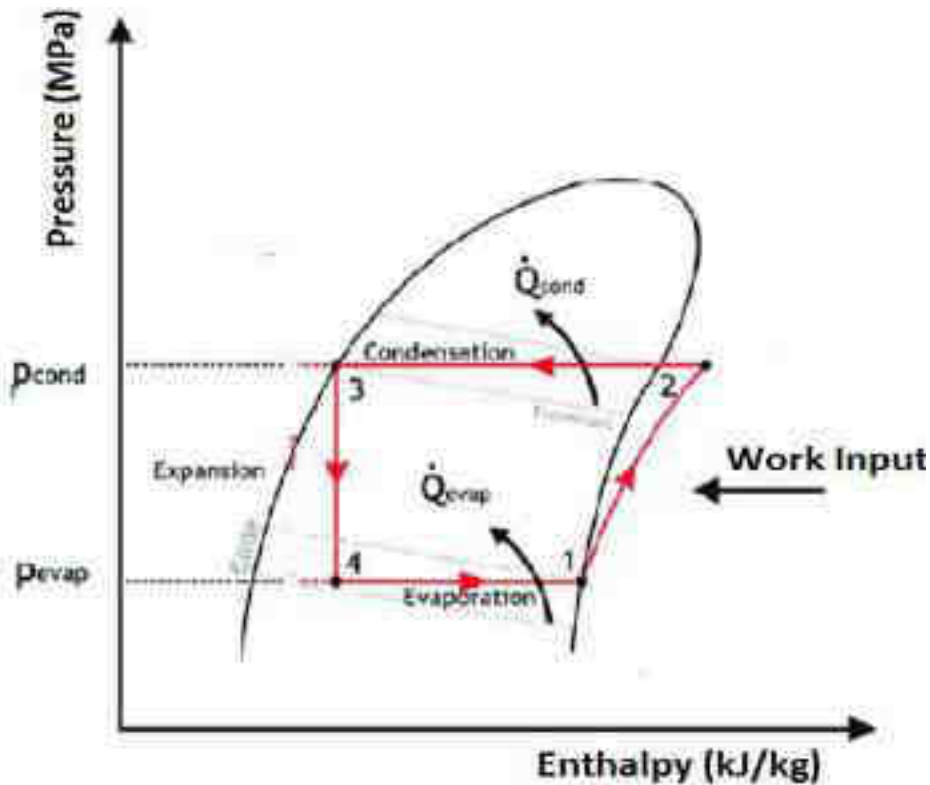

Solution

$$h_1 = 195 \text{ kJ/kg}$$

$$h_3 = 65 \text{ kJ/kg}$$

$$h_4 = h_3$$

Refrigerating effect

$$= m (h_1 - h_4)$$

$$= 1 (195 - 65)$$

$$= 130 \text{ kW}$$

Q.6

For simple vapour compression cycle, enthalpy at suction = 1600 kJ/kg, enthalpy at discharge from the compressor = 1800 kJ/kg, enthalpy at exit from condenser = 600 kJ/kg. What is the COP for this refrigeration cycle?

- a) 3.3 b) 5.0 c) 4 d) 4.5

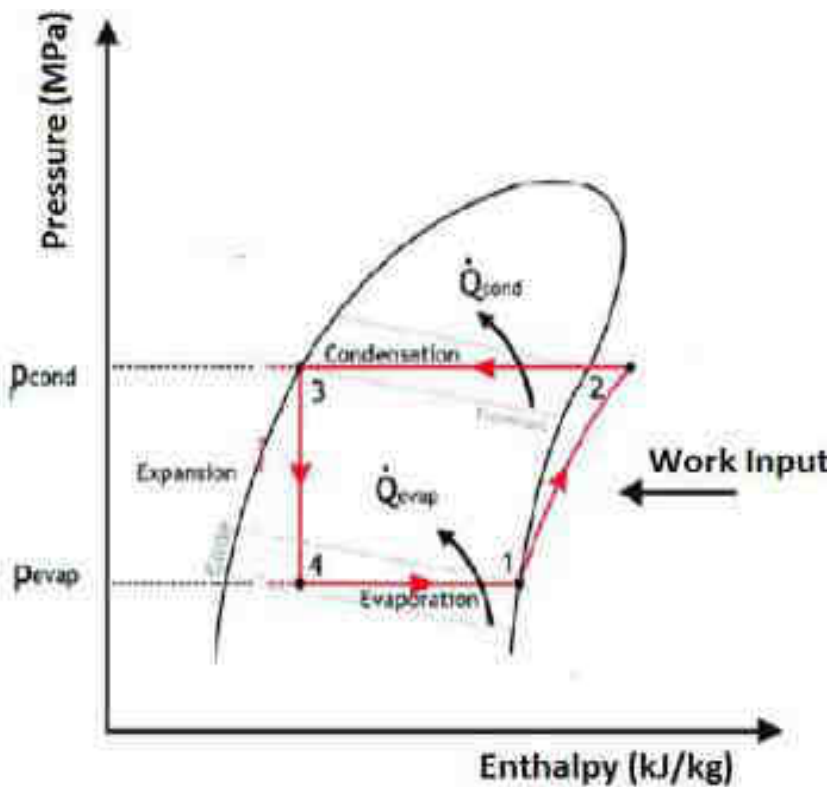

Solution

$$h_1 = 1600 \text{ kJ/kg}$$

$$h_2 = 1800 \text{ kJ/kg}$$

$$h_3 = 600 \text{ kJ/kg}$$

$$h_4 = h_3$$

$$COP = \frac{(h_1 - h_4)}{(h_2 - h_1)}$$

$$COP = \frac{1600 - 600}{1800 - 1600}$$

$$COP = 5$$

Q.7 & Q.8

A refrigerator operates between 120kPa and 800kPa in an ideal vapour compression cycle with R-134a as the refrigerant. The refrigerant enters the compressor as saturated vapour and leave the condenser as saturated liquid. The mass flow rate of the refrigerant is 0.2 kg/s. Properties of R134a are as follows:

P(kPa)	T(C)	h_f (kJ/kg)	h_g (kJ/kg)	S_f (kJ/kgK)	S_g (kJ/kgK)
120	-22.32	22.5	237	0.093	0.95
800	31.31	95.5	267.3	0.354	0.918

Superheated R134a

P(kPa)= 800

T (deg.C)= 40

h (kJ/kg) =276.45

S (kJ/kgK)= 0.95

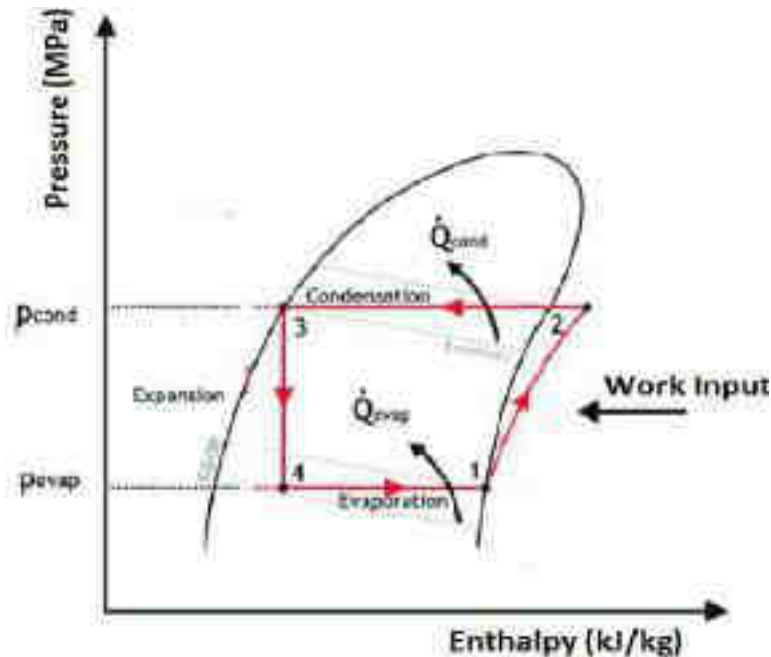

Kindly note:

$$H_1 = 237 \text{ kJ/kg}$$

$$h_2 = 276.45 \text{ kJ/kg}$$

$$h_3 = 95.5 \text{ kJ/kg}$$

$$h_4 = h_3 = 95.5 \text{ kJ/kg}$$

Q.7

- The power required for compressor in kW is
 - (a) 5.94
 - (b) 1.83
 - (c) 7.9
 - (d) 39.5

- **Solution:**

Power required for the compressor

$$= m (h_2 - h_1)$$

$$= 0.2 (276.45 - 237)$$

$$= 7.9 \text{ kW}$$

Q.8

- The rate at which heat is extracted, in kJ/s from the refrigerated space is
 - (a) 28.3
 - (b) 42.9
 - (c) 34.4
 - (d) 14.6

- Solution:**

$$h_1 = 237 \text{ kJ/kg}$$

$$h_2 = 276.45 \text{ kJ/kg}$$

$$h_3 = h_4 = 95.5 \text{ kJ/kg}$$

Mass flow rate

$$m = 0.2 \text{ kg/s}$$

Rate of heat extracted

$$Q_{4-1} = m (h_1 - h_4)$$

$$= 0.2 (237 - 95.5)$$

$$= 28.3 \text{ kW}$$

Q.11

The vapour compression refrigeration cycle is represented as shown in the figure below, with state 1 being the exit of the evaporator. The coordinate system used in this figure is

- (a) p-h
- (b) T-s
- (c) p-s
- (d) T-h

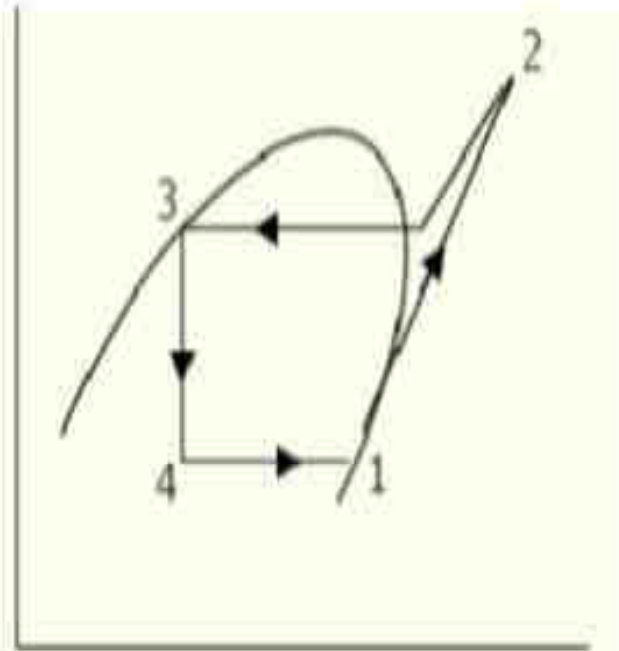

[GATE-2005]

Ans. (d)

Thanks

Measurement Of Pressure

Harmesh Kumar
Asstt. Prof., Deptt. of Mech. Engg.
BBSBEC, Fatehgarh Sahib

Instructional Objectives

Understands

- Different methods for measurement of pressure using elastic transducers
- Construction and working principle of
 - Diaphragms
 - Bellows
 - Bourdon Tube Pressure Gauges

Measurement of Gauge Pressure

- Mainly carried out by using elastic elements:
 - Diaphragms
 - Bellows
 - Bourdon tubes.
- These elastic elements change their shape with applied pressure and the change of shape can be measured using suitable deflection transducers.

Measurement of Gauge Pressure

Deflection Transducer

- This transducer uses an **elastic material to convert pressure to displacement** e.g. stainless steel, brass.
- The displacement will be proportionate to the value of pressure exerted.
- Suitable to be used in an automatic control system.
- The main element used is in the shape of Bourdon tube, bellow or diaphragm.
- The secondary element is the element that will **convert the displacement to electrical signals where the displacement can be detected through resistivity change, inductance or capacitance.**

Diaphragms

- Diaphragms may be of three types:

(based on the applied pressure and the corresponding displacements)

- **Thin plate**
 - **Membrane**
 - **Corrugated diaphragm**
- Thin plate (fig. 1(a)) is made by machining a solid block and making a **circular cross sectional area with smaller thickness in the middle.**
 - It is used for measurement of relatively higher pressure.

Diaphragms

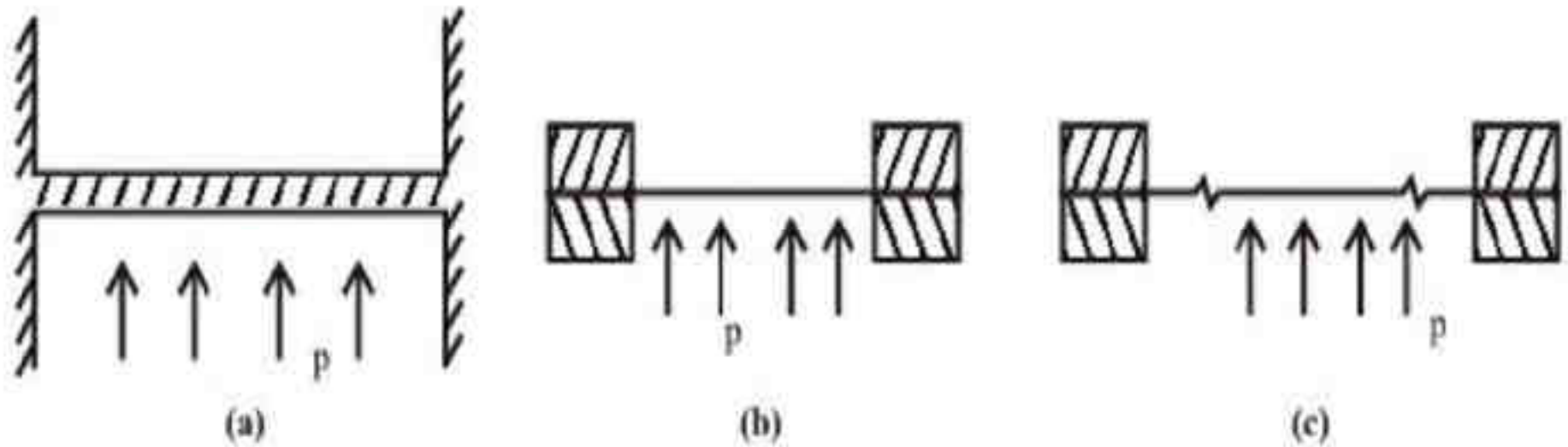
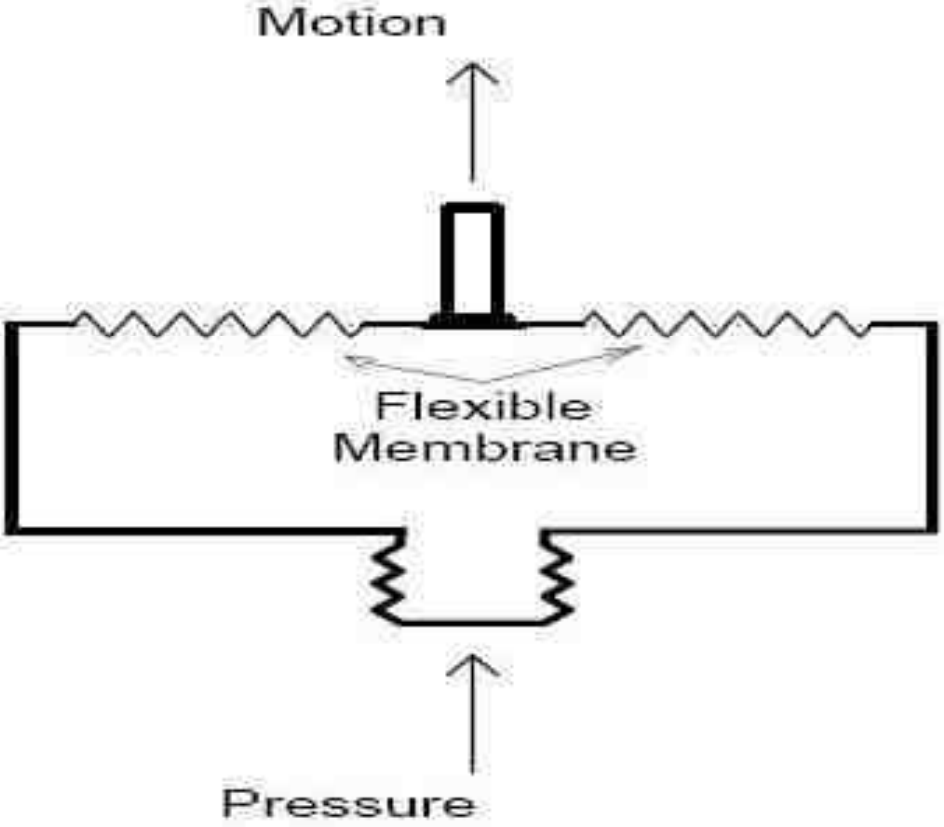

Fig. 1 (a) Thin plate, (b) Membrane and (c) Corrugated diaphragm.

Diaphragms



Diaphragms

- In a membrane the sensing section is glued in between two solid blocks as shown in fig. 1(b).
- The thickness is smaller; as a result, when pressure is applied on one side, the displacement is larger. Hence **increase in sensitivity** of the system.
- The sensitivity can be further enhanced in a **corrugated diaphragm** (fig. 1(c)), and a large deflection can be obtained for a small change in pressure; however **at the cost of linearity**.
- The materials used are **Bronze, Brass, and Stainless steel**.

Diaphragms

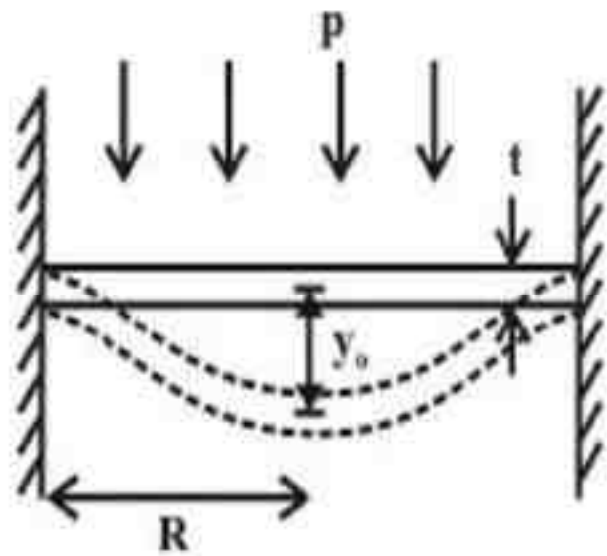

Fig. 2 Displacement of a diaphragm

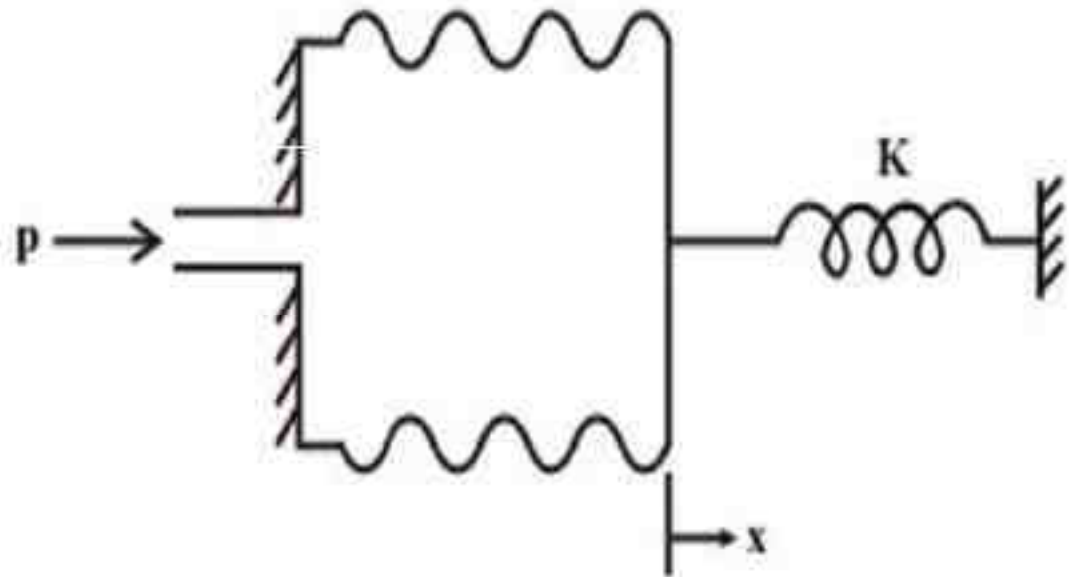

Fig. 3 Bellows

Diaphragms

When pressure is applied to a diaphragm, it deflects and the maximum deflection at the centre (y_0) can be measured using a displacement transducer. For a thin plate, the maximum deflection y_0 is small ($y_0 < 0.3t$) and referring fig. 2, a linear relationship between p and y_0 exists as:

$$y_0 = \frac{3}{16} p \frac{(1-\nu^2)}{Et^3} R^4$$

where, E = Modulus of elasticity of the diaphragm material, and
 ν = Poisson's ratio.

However, the allowable pressure should be less than:

$$p_{\max} = 1.5 \left(\frac{t}{R} \right)^2 \sigma_{\max}$$

where, σ_{\max} is the safe allowable stress of the material.

Diaphragms

- For a corrugated diaphragm, it is difficult to give any definite mathematical relationship between p and y
- But the relationship is also **highly nonlinear.**

Bellows

- Bellows (fig. 3) are made with a number of convolutions from a soft material and **one end of it is fixed**, wherein air can go through a port. **The other end of the bellows is free to move.**
- The displacement of the free end increases with the number of convolutions used.
- Number of convolutions varies between 5 to 20.

Bellows

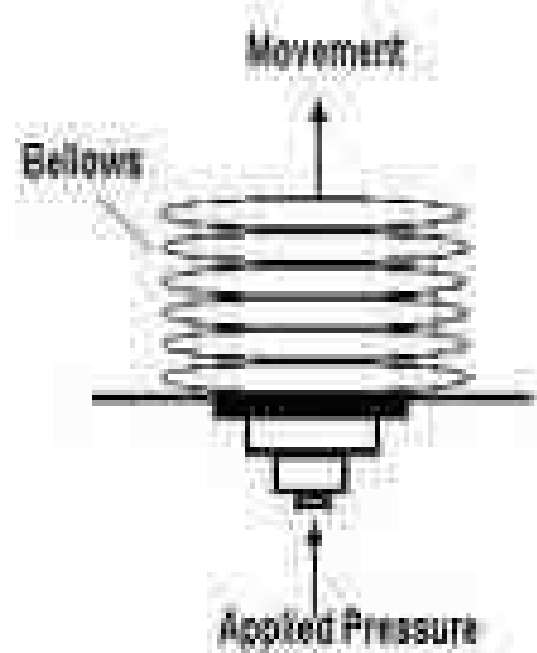
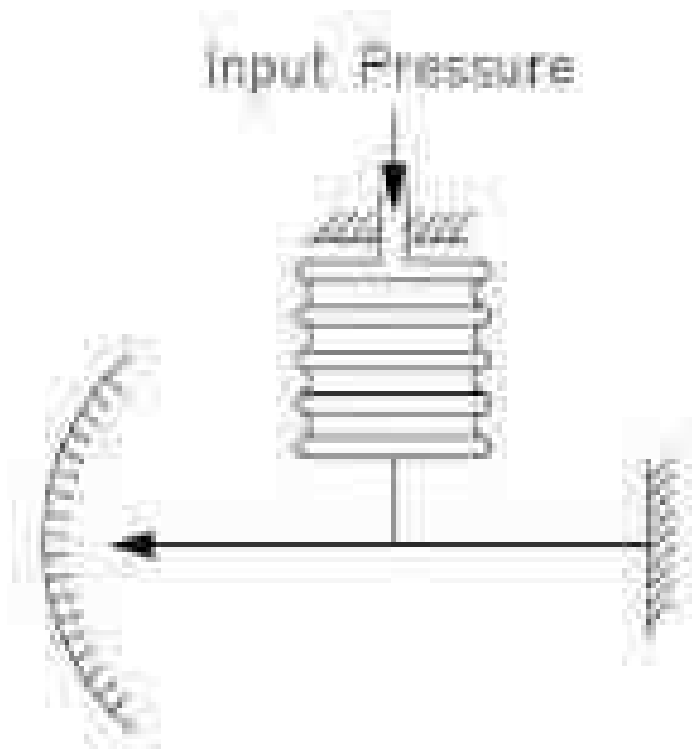

Bellows

- Often an external spring is used opposing the movement of the bellows; as a result a linear relationship can be obtained from the equation:

$$p.A = k.x$$

where, A is the area of the bellows

k is the spring constant and

x is the displacement of the bellows.

- **Phosphor Bronze, Brass, Beryllium Copper, Stainless Steel** are normally used as the materials for bellows.
- Bellows are manufactured either by (i) turning from a solid block of metal, or (ii) soldering or welding stamped annular rings, or (iii) rolling (pressing) a tube.

Bellows

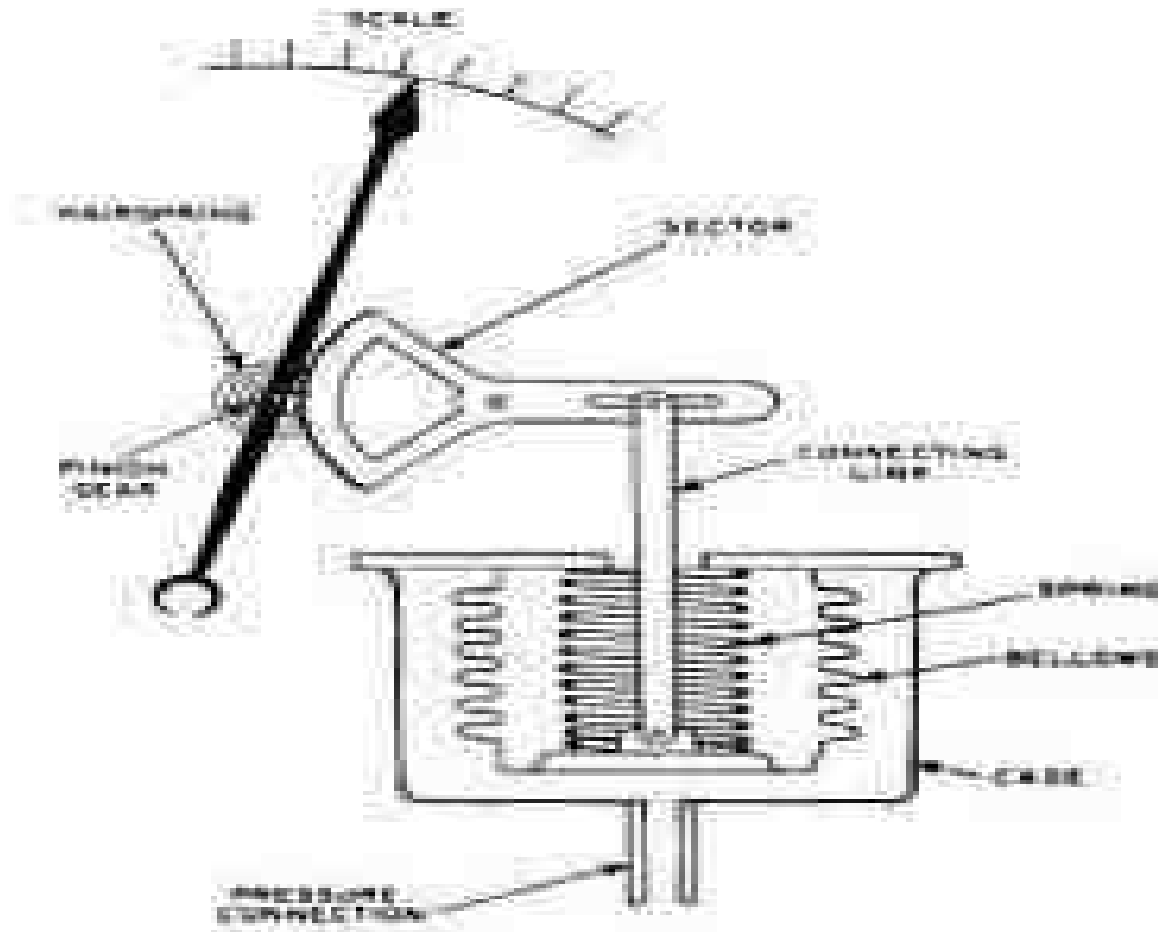

Bourdon Tube

- Bourdon tube pressure gages are extensively used for local indication.
- Bourdon tube pressure gages can be used to measure over a wide range of pressure: from vacuum to pressure as high as few thousand psi.
- It is basically consisted of a **C-shaped hollow tube, whose one end is fixed and connected to the pressure tapping, the other end free**, as shown in fig. 4.
- The cross section of the **tube is elliptical**.

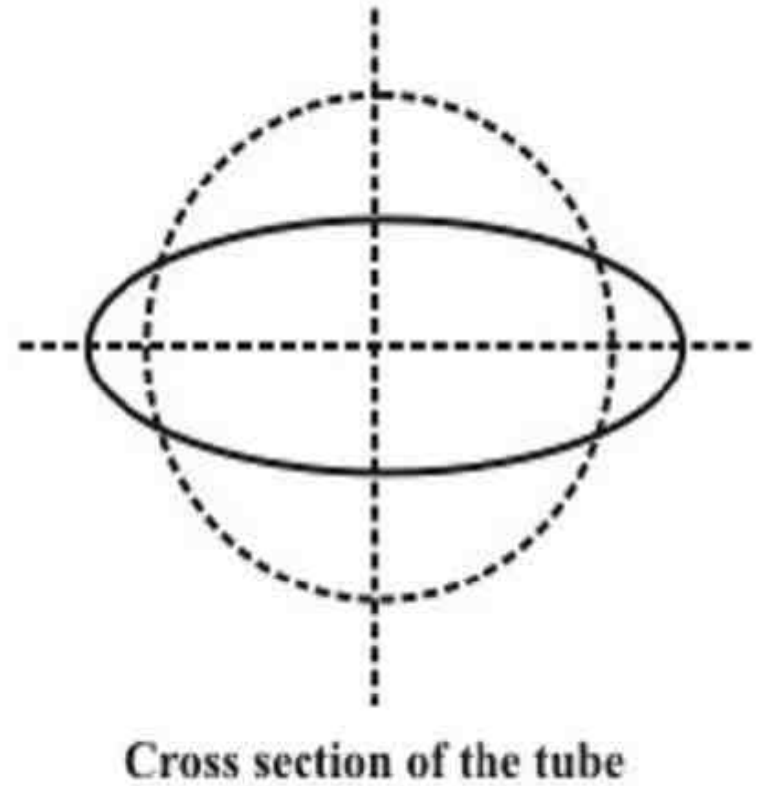
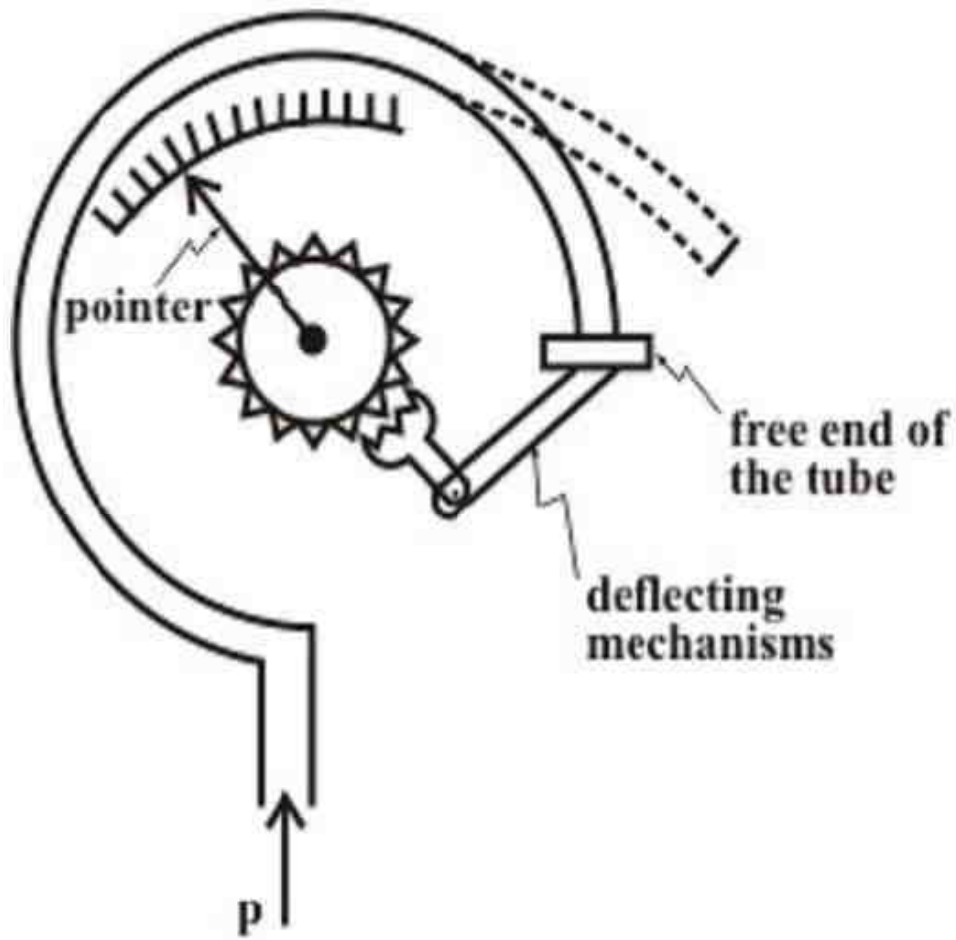

Fig. 4 Bourdon tube

Bourdon Tube

- When pressure is applied, the elliptical tube **tries to acquire a circular cross section;**
- As a result, stress is developed and the **tube tries to straighten up.**
- Thus the free end of the tube moves up, depending on magnitude of pressure.
- A deflecting and indicating mechanism is attached to the free end that rotates the pointer.
- The materials used are commonly Phosphor Bronze, Brass and Beryllium Copper.
- For a 2" overall diameter of the C-tube the useful travel of the free end is 1/8" approximately

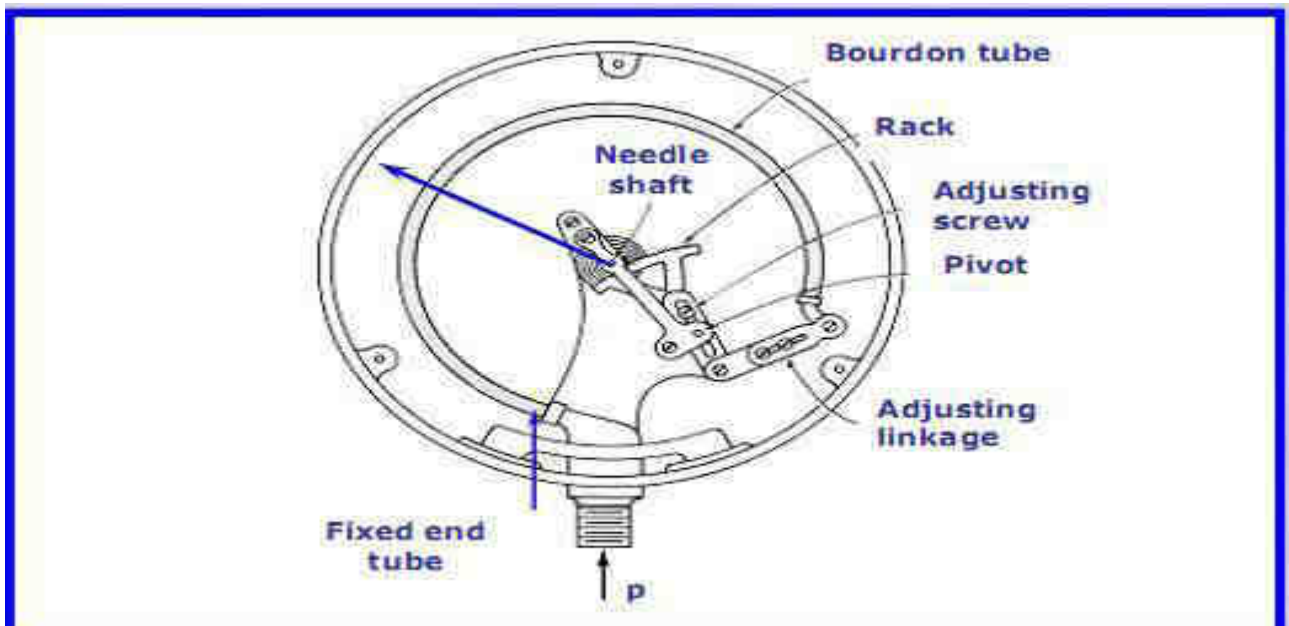

Figure 68 Schematic of a Bourdon pressure gage



Figure 69 Photograph of a Bourdon gage taken from the web
 (Dr. Pravin Varma, [Mount Allison University](http://www.mountallison.ca), Sackville, New Brunswick Canada)

Bourdon Tube

$$\Delta a = 0.05 (a.p/E) (r/t)^{0.2} (x/y)^{0.33}(x/t)^3$$

Δa - Displacement of tube tip

a- Length of tube

p- Intensity of pressure

t- Wall thickness of tube

x&y- Dimensions of tube

E- Modulus of elasticity

- **Displacement of tip varies**
 - **inversely to the wall thickness of the tube**
 - **Directly to the length of the arc**
- **Length of arc can be increased further by two ways**
 - **Spiral**
 - **Helix form**
- **Avoiding the need for further magnification by geared sector and pinion as in Bourdon tube pressure gauge**

Spiral type pressure gauge

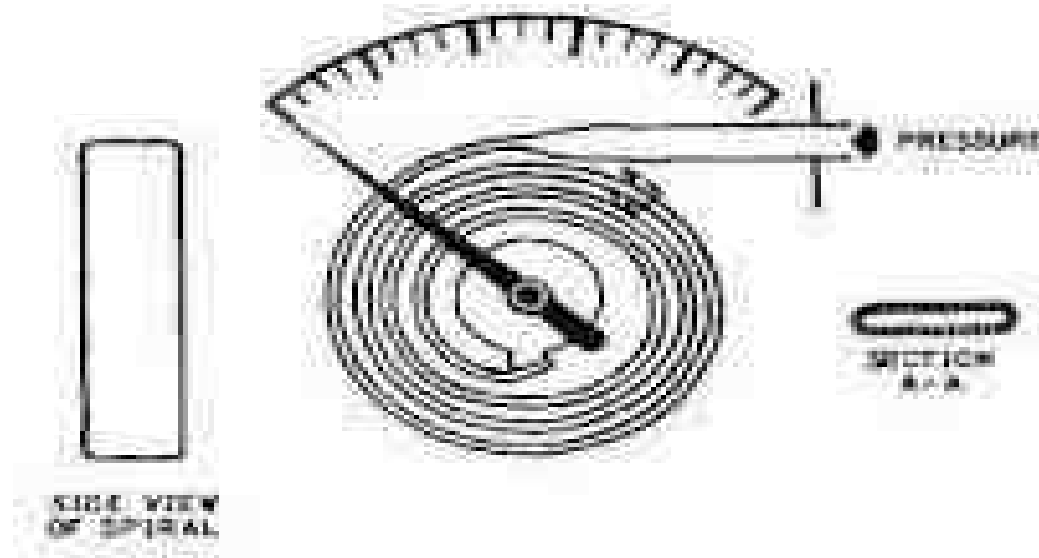

Basic forms of tubes used for pressure sensors

Though the C-type tubes are most common, other shapes of tubes, such as **helical**, **twisted** or **spiral tubes** are also in use.

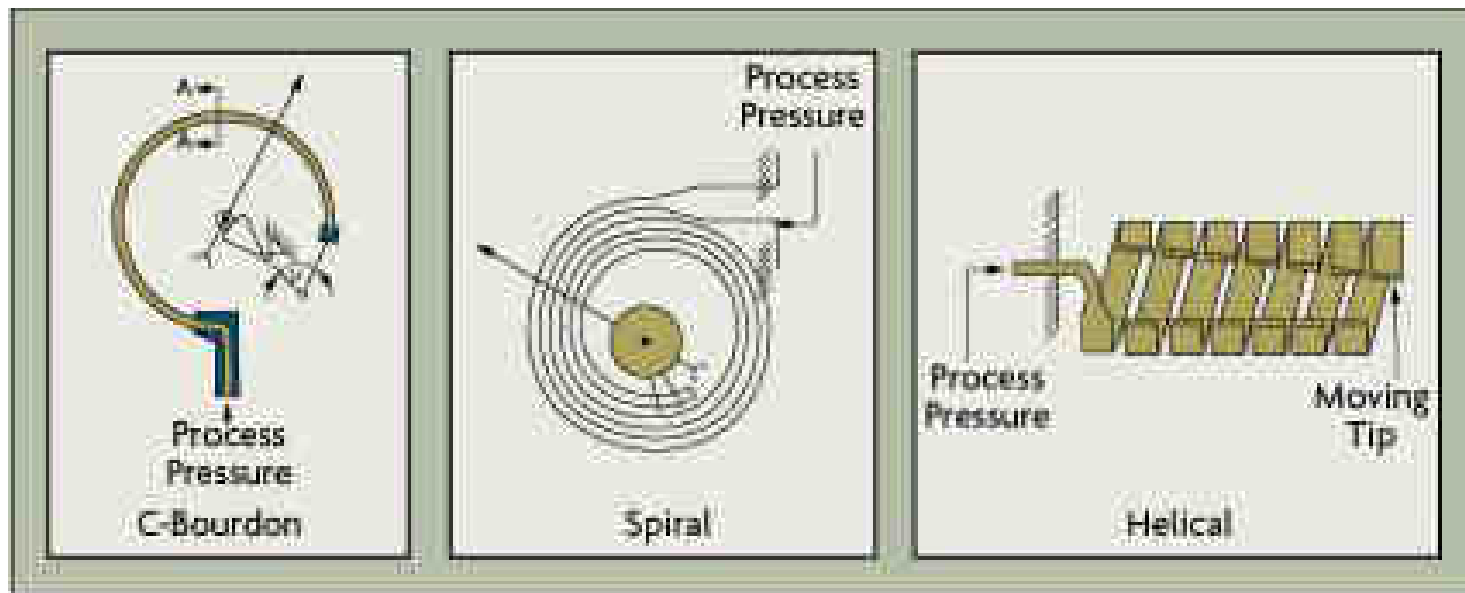

Bourdon Tube

Advantage

- Simple in construction and design
- Available in several different ranges
- Capable to measure gauge, absolute and differential pressure
- Excellent sensitivity
- Easy calibration

Disadvantages

- Susceptibility of shock and vibration
- Slow response to pressure changes
- Unsuitable for low pressure applications

Example 1:

i. Bellow-resistance pressure sensor

- The pressure is proportionate to the resistivity.
- The resistance change is detected by displacement of sliding contact in the resistance element.

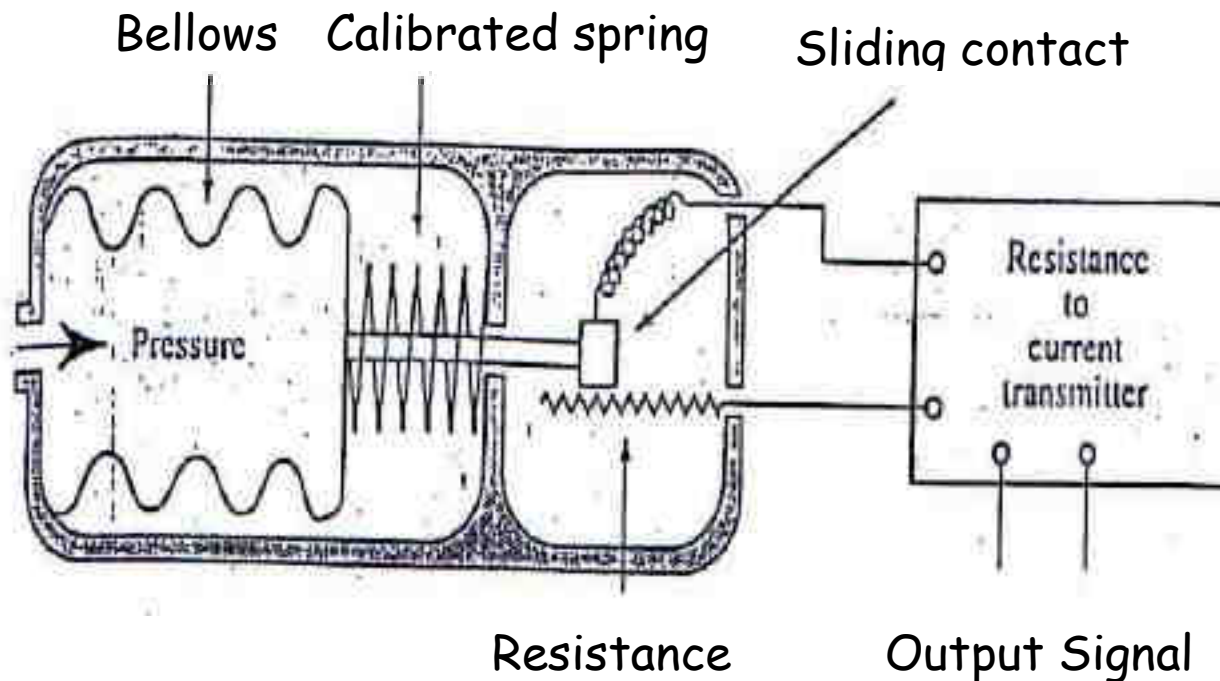

Example 2:

ii. Bellow-inductance pressure sensor

- The pressure is proportionate to the inductance change which is detected from the displacement of the core in the wire coil.
- The core movement will produce AC signal output which will give the value and direction of inductance.
- LVDT (linear variable differential transformer) demodulator is used to convert the AC output to DC.

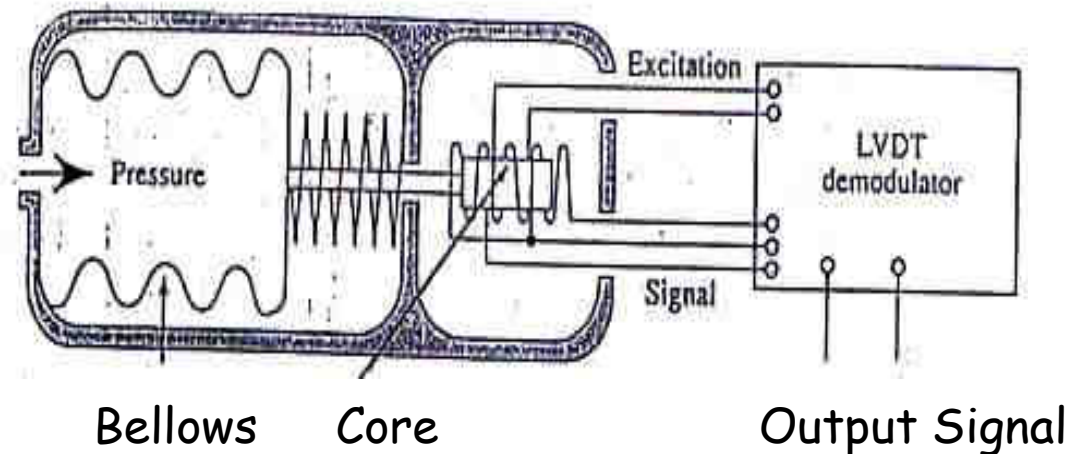

Example 3:

iii. Diaphragm-capacitance pressure sensor

- The pressure is proportionate to the capacitance change at the output through dielectric change.
- Pressure from the sensor element causes the diaphragm to move towards the plate and produces dielectric change.

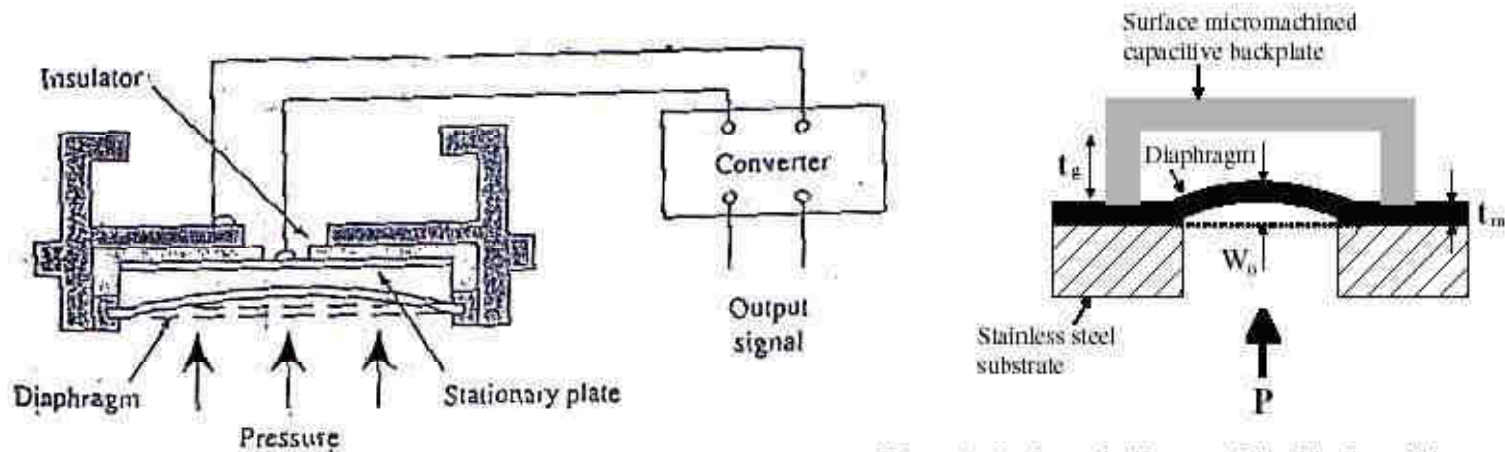
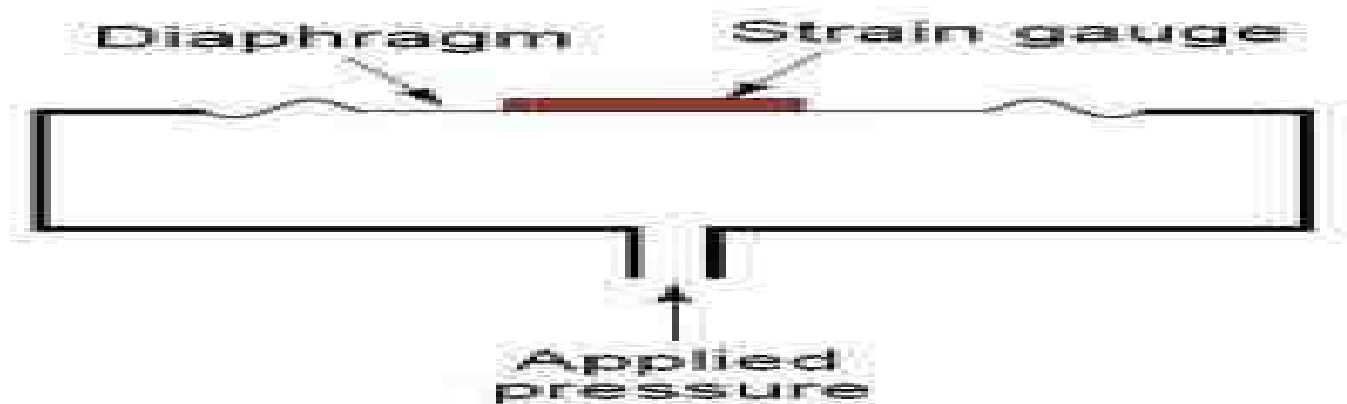

Figure 4. A schematic diagram of the side view of the capacitive pressure sensor.

Example 4:

iv. Diaphragm-Strain gauge pressure sensor



Example 4:

iv. Diaphragm-Strain gauge pressure sensor

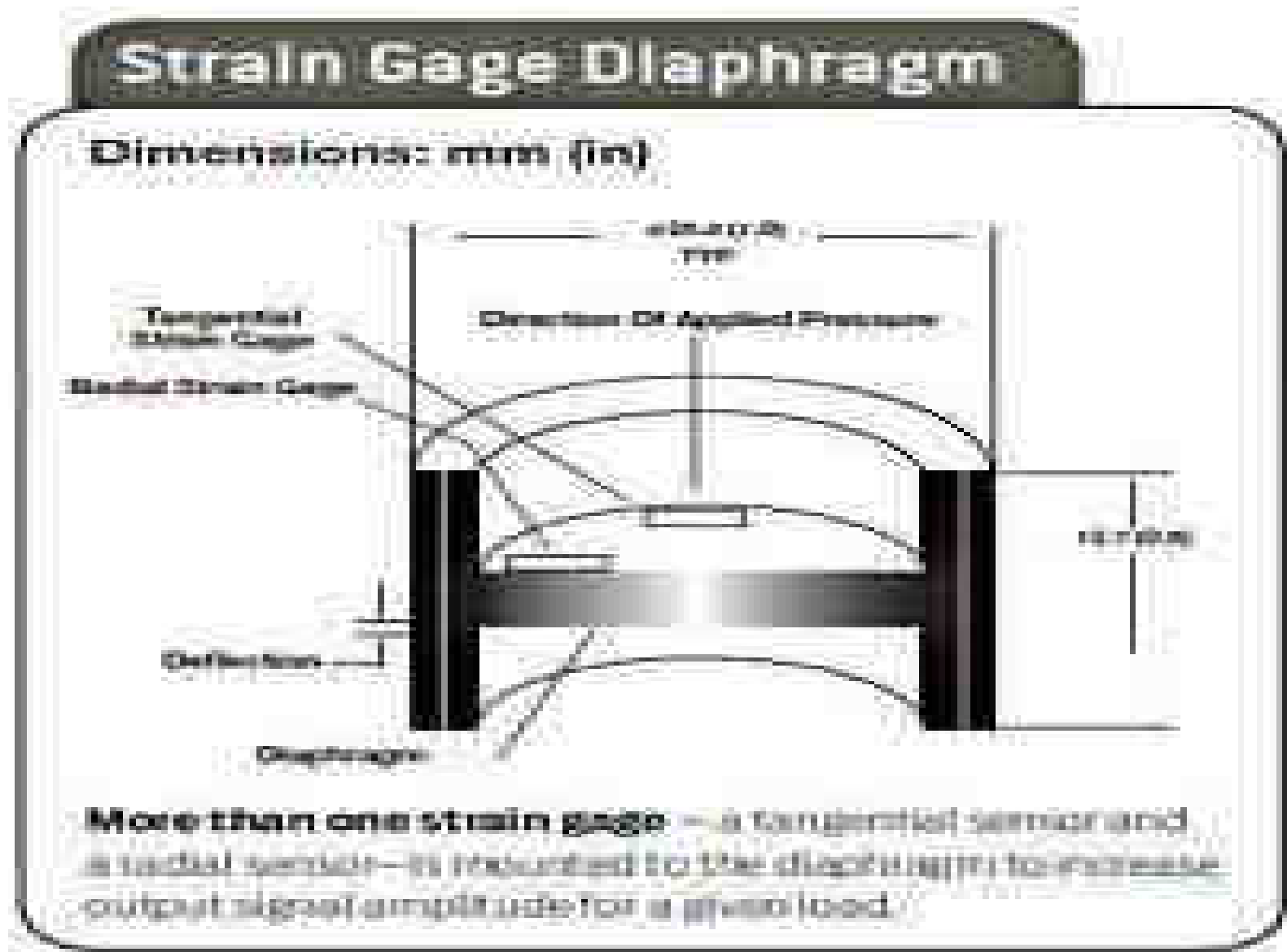

Example 4:

Bellow-Strain gauge differential pressure sensor

Pressure Measurement With Strain Gauge on Bellows

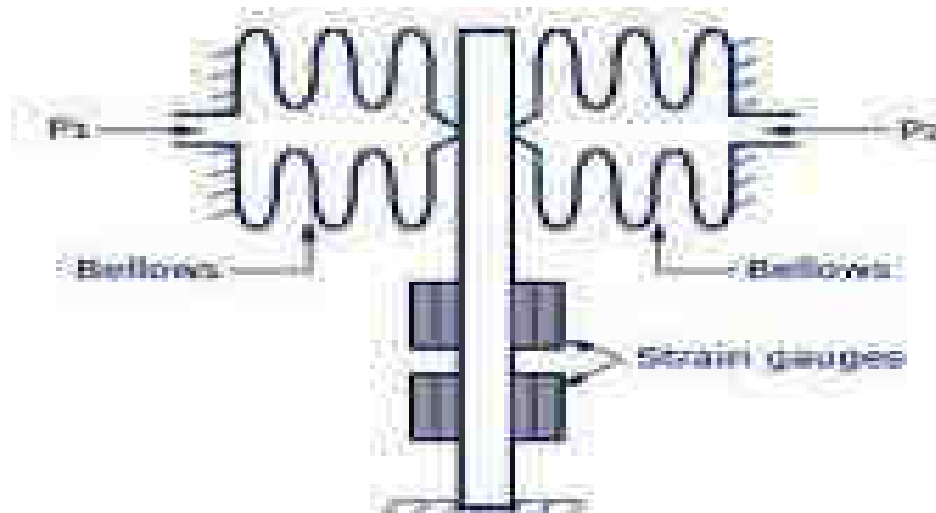

Any Question?



Typical Pressure Detector System

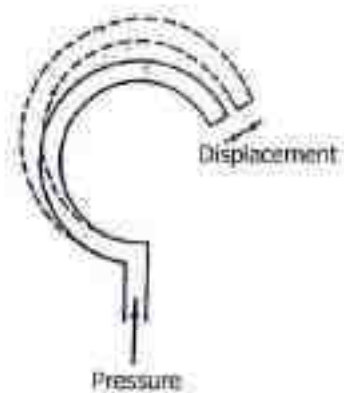

a) A Circular Bourdon pressure element

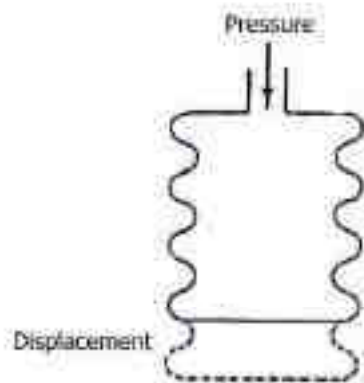

b) A bellows pressure element

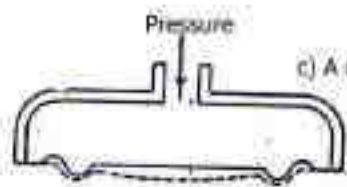

c) A diaphragm pressure element

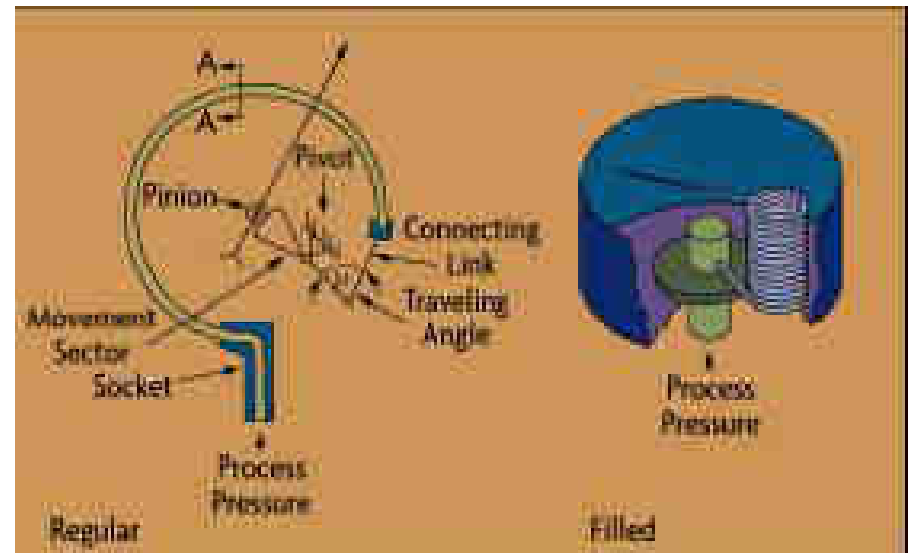

The Main Typical Element Used In A Deflection Type Pressure Sensor

The Refrigerant and Other Substances for Refrigeration

The Refrigerant and Other Substances for Refrigeration

- ◆ Introduction of Refrigerants
- ◆ Environmental Friendly Refrigerants

Introduction of Refrigerants

Introduction of Refrigerants

- ◆ [Refrigerant in vapor compression refrigeration](#)
- ◆ [Refrigeration Characteristics of refrigerants](#)
- ◆ [Some Important Physical/Chemical Properties of Refrigerants](#)
- ◆ [Nomenclature of Refrigerants](#)
- ◆ [Secondary Refrigerants](#)
- ◆ [References](#)

Refrigerant in vapor compression refrigeration

- ◆ The working substance in a refrigeration system is called the refrigerant.
- ◆ There are lots of refrigerants, including gas, liquid and solid refrigerants.

Refrigeration Technology



- ◆ There are many natural and artificial substances have been used in mechanical driven and thermal driven vapor compression refrigeration systems.
- ◆ In lithium bromide vapor absorption refrigeration system, H_2O is used as a refrigerant and $LiBr$ is an absorbent ; in NH_3 vapor absorption refrigeration system, NH_3 is a refrigerant; is an absorbent.
- ◆ Water H_2O is also used as a refrigerant both in vapor adsorption and in vapor jet refrigeration cycles. In mechanical driven vapor compression refrigeration, NH_3 , CO_2 , chlorofluorocarbons (CFCs), hydrochlorofluorocarbons (HCFCs), hydrofluorocarbons (HFCs), azeotropic and zeotropic mixtures, inorganic compounds, hydrocarbons, and others are used as refrigerants.

.Refrigeration Characteristics of refrigerants

- ◆ The pressure- enthalpy diagram is the usual graphic means of presenting refrigerant properties and its cycles.
- ◆ A typical vapor compression refrigeration cycle has been shown in Fig.2-1.

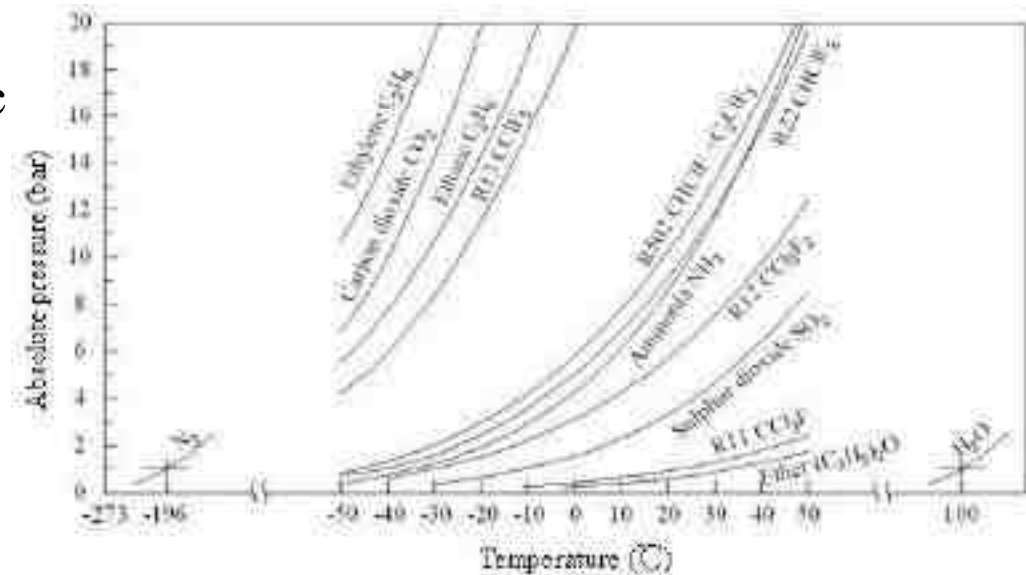

Fig 7-1, The saturated pressure with temperature of some refrigerants

1. Appropriate temperature and pressure characteristics

- ◆ The saturated pressure with temperature is an important property of refrigerant.
 - 1) It is desired for the pressure at evaporating temperature to be above atmospheric, to avoid inward leakage of air.
 - 2) The pressure at the corresponding condensing temperature should not be excessive, so that extra strength high-side equipment is not required.
 - 3) Low compression ratio is desirable, because the degree of complication and difficulty of a compressor increases directly with the compression ratio.
 - 4) Discharge temperature of compressor should not be excessive, to avoid problems as breakdown or dilution of the lubricating oil, decomposition of the refrigerant, or formation of contaminants such as sludge or acids. All of these can lead to compressor damage.

2. High latent heat of vaporization and low specific volume of the refrigerant at the entry to compressor

- ◆ A high latent heat of vaporization and a low specific volume of the refrigerant at entry to the compressor are desirable for smaller equipment and pipe size at given cooling capacity.
- ◆ High latent heat means there is a high refrigeration effect.
- ◆ For example, R11 has a much larger specific volume of suction vapor of compressor than those of refrigerants of R22, R502 and R717.
- ◆ That means it requires a higher volumetric flow rate to produce the same amount of cooling capacity.
- ◆ Therefore, R11 is usually used with centrifugal compressors because they are good at handling large volumetric flow rate.

3. Lower compression work

- ◆ In order to get high COP , both high refrigeration effect and low compression work must be considered in combination.
- ◆ For example, R717 (ammonia) has a refrigerating effect q_1 much larger than other refrigerants, but its compression work w is also high, as a result, COP of ammonia has the same order of magnitude as that of the other refrigerants.

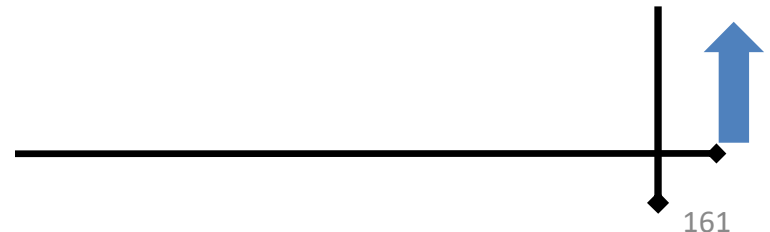

Some Important Physical/Chemical Properties of Refrigerants

- ◆ Any substance which has appropriate thermal properties can be used as a refrigerant, but in practice the choice is limited by many factors such as toxicity, flammability, chemical stability, and the behaviors of the refrigerant with lubricating oil, water and construction materials.

1. Safety group classification

- ◆ In the Standard 34, the refrigerants have been classified into safety groups in the following ways:
- ◆ The safety classifications consist of two alphanumeric characters (e.g. A2 or B1).
- ◆ In which the capital letter indicates the toxicity and the Arabic numeral denotes the flammability.

(1) Toxicity classification

- ◆ Refrigerants are assigned to one of two classes: A or B based on the following exposure:
 - ◆ **Class A** signifies refrigerants for which toxicity has not been identified at concentrations less than or equal to 400 ppm, based on data used to determine Threshold Limit Value-Time-Weighted Average (TLV-TWA) or consistent indices.
 - ◆ **Class B** signifies refrigerants for which there is evidence of toxicity at concentrations below 400 ppm, based on data used to determine TLV-TWA or concentration indices.

(2) Flammability Classification

- ◆ Refrigerants are assigned to one of three classes: 1, 2 or 3 based on flammability.
 - ◆ **Class 1** indicates refrigerants that do not show flame propagation when tested in air at 101kpa and 21°C.
 - ◆ **Class 2** signifies refrigerants having a lower flammability limit (LFL) concentration of above 0.10 kg/m³ in air at 21 °C and 101 kpa and a heat of combustion below 19,000 kJ/kg.
 - ◆ **Class 3** indicates refrigerants that are highly flammable, as identified by an LFL concentration less than or equal to 0.10 kg/m³ at 21 °C and 101 kPa, or a heat of combustion greater than or equal to 19,000 kJ/kg.

Refrigeration Technology

- By combining toxicity and flammability criteria, a matrix is obtained which classifies a refrigerant into class A1, A2, A3, B1, B2, or B3 as shown in Tab.7-4.

		SAFETY GROUP	
INCREASING FLAMMABILITY	HIGHER FLAMMABILITY	A3	B3
	LOWER FLAMMABILITY	A2	B2
	NO FLAME PROPOGATION	A1	B1
		LOWER TOXICITY	HIGHER TOXICITY
		INCREASING TOXICITY	

Tab.7-4, Safety classification of some refrigerants

3. Chemical Stability

- ◆ A refrigerant must be chemically stable in the temperature range it is exposed to.
- ◆ Chemical stability means that the refrigerant should not dissociate at the temperatures encountered in the refrigerator.
- ◆ Decomposition can result in the production of contaminants such as acids, sludge, or non-condensable gases.
- ◆ Chemical stability also means that the refrigerant should not decompose at the catalytic conditions by the presence of oil, water, metallic impurities.

4. Compatibility with Construction Materials

- ◆ A refrigerant should not react chemically with any materials it encounters in the system.
- ◆ The principal incompatibilities consist in ammonia and copper, and methyl chloride and aluminum.
- ◆ Ammonia can be used with iron, steel and aluminum, and methyl chloride with iron, steel and copper.
- ◆ The fluorinated refrigerants can be used with iron, steel, copper and aluminum.
- ◆ However, alloying elements in aluminum, particularly magnesium and manganese, occasionally give trouble and should be avoided.

Refrigeration Technology



- ◆ The refrigerant and its lubricant should be compatible with the compressor materials, piping, sealing devices and others.
- ◆ Materials should be qualified for use by performing compatibility testing under the range of conditions that will be encountered during use.
- ◆ The compatibility testing usually includes chemical and thermal stability of refrigerant-lubricant mixtures with metals, compatibilities of refrigerant-lubricant mixtures with motor materials, elastomers and engineering plastics.

5. Relation of lubricating oil and refrigerant

- ◆ In most refrigerating machines oil is used not only to lubricate the bearings and running surfaces, but also to prevent refrigerant leakage.
- ◆ A refrigerant should not compromise the lubricating quality of the oil, either by chemical or physical action.
- ◆ Liquid ammonia and oil are almost immiscible, so an oil separator is usually used.

Refrigeration Technology



- ◆ However, most CFCs, HCFCs and HFCs are miscible with lubricating oils to a relatively high proportion.
- ◆ The solubility of refrigerant vapor in oil is important in the crankcase of the compressor.
- ◆ Dissolved refrigerant can dilute the oil and reduces its viscosity.
- ◆ Refrigerant-oil miscibility is desirable to a degree that oil can be carried to wearing parts, but excessive miscibility can result in ineffective lubrication.

6. Behavior of refrigerant with water

- ◆ Water has very different miscibilities with different refrigerants, and this fact has an important impact on the operation of refrigeration systems.
- ◆ Refrigerant grade anhydrous ammonia is a clear, colorless liquid or gas, free from visible impurities.
- ◆ It is at least 99.95 percent pure ammonia.
- ◆ Water is miscible with ammonia in all proportions, and forms solutions with very low freezing points.
- ◆ Water is never therefore deposited as ice inside the system.
- ◆ Ammonia, especially in the presence of moisture, reacts with and corrodes copper, zinc, and many alloys.

Refrigeration Technology



- ◆ On the other hand, the solubility of water in refrigerants of CFCs, HCFCs and HFCs is minute.
- ◆ It is only about 0.0026% by mass at 0 for R12, and about 0.06% for R22, therefore any water in the system above the small amount which can be dissolved by the refrigerant, must be present as free water.
- ◆ This can freeze wherever the temperature drops to 0.
- ◆ The ice could block the orifice of the expansion valve or capillary tube.



Nomenclature of Refrigerants

1. History of refrigerant nomenclature

- ◆ The naming system was firstly developed only for chlorofluorocarbons (CFCs) by T. Midgley, Jr. and A. L. Henne in 1929, and further refined by J. D. Park.
- ◆ The number was originally part of the registered trade name, but was later donated to the industry by Du Pont in order to avoid confusion and proliferation of different numbers for the same product.
- ◆ Originally, organic molecules that contained chlorine and fluorine were all referred to as CFCs.

Refrigeration Technology



- ◆ Today, the group is subdivided into CFCs, HCFCs, and HFCs . The naming system is developed to all refrigerants then.
- ◆ The full nomenclature system has been formalized by the American Society of Heating Refrigeration & Air Conditioning Engineers (ASHRAE) under ANSI/ASHRAE Standard 34-1992.
- ◆ The specified ANSI/ASHRAE prefixes were FC (FluoroCarbon), or R (Refrigerant), but today most are prefixed by more specific classifications - such as CFC, HCFC, and HFC.
- ◆ This internationally recognised system of numbering refrigerants is somewhat obscure, but straightforward in application .

2. The fluorinated derivatives of the saturated hydrocarbons

- ◆ Saturated hydrocarbons: CH₄, C₂H₆, C₃H₈, ..., C_aH_{2a+2},
- ◆ **Standard nomenclature of fluorinated derivatives of the saturated hydrocarbons:**



- ◆ The refrigerants are numbered with an R-, followed by 2-5 numbers and / or letters, which reflect its chemical composition given by the rules of the fluorocarbons numbering system.

Refrigeration Technology



- ◆ Isomers are identified with lower cases (ex R 134a).
- ◆ **The first** digit is one unit lower than the number of carbon atoms in the molecule which is $(a-1)$. If the molecule contains only one carbon atom, the first digit is omitted.
- ◆ **The second** digit is one unit greater than the number of hydrogen atoms in the molecule which is $(b+1)$.
- ◆ **The third** digit is equal to the number of fluorine atoms in the molecule, which is (d) .

3. The unsaturated hydrocarbons and their halogenated derivatives

- ◆ assigned 1000 series numbers
- ◆ Unsaturated hydrocarbons such as C₂H₄ , C₃H₆ , C₄H₈ , C_aH_b,

Where $b < 2a + 2$

- ◆ **Standard nomenclature of halogenated derivatives of unsaturated hydrocarbons:**

$C_a H_b Cl_c F_d$ is denoted $R_{1(a-1)(b+1)(d)}$

Refrigeration Technology



- ◆ The 1000 series has been assigned to unsaturated hydrocarbons and their halogenated derivatives.
- ◆ **The first digit “1”** is the number of carbon to carbon double bonds;
- ◆ **The second digit** is one less than the number of carbon (C) atoms which is $(a-1)$;
- ◆ **The third digit** is one more than the number of hydrogen (H) atoms which is $(b+1)$;
- ◆ **The fourth digit** is the number of fluorine (F) atoms which is (d) .

4. Zeotropic blends assigned 400-series numbers $R4xx$

- ◆ **Azeotrope :**
 - ◆ A liquid mixture of two or more substances that retains the same composition in the vapor state as in the liquid state when distilled or partially evaporated under a certain pressure.
- ◆ **Zeotrope** (also known as a non-azeotropic mixture):
 - ◆ The concentrations of the liquid and the vapor phase are never equal.
 - ◆ This creates a temperature glide during phase change (at which point the concentrations of the vapor and the liquid are continually changing).
- ◆ Zeotropic mixtures are the most common type of refrigerant blend.
- ◆ An example of a zeotropic mixture is ammonia and water.

◆ Near-azeotropic :

- ◆ For a near-azeotropic mixture, the concentrations of vapor and liquid at a given temperature and pressure differ only slightly.
- ◆ Most azeotropic refrigerant mixtures become near-azeotropic when the pressure or temperature is varied from the azeotrope point.
- ◆ R-410A (which is also known as AZ-20 under the Allied Signal patent) is a near-azeotropic mixture of R-32 and R-125 (50%/50% of mass percent).

Refrigeration Technology

- ◆ Zeotropes are designated by a three digit number beginning with the number “4”.
- ◆ For example the 60/40 weight % mixture of R-12 and R-114 would be R-400 (60/40).
- ◆ Zeotropes having the same components with different amounts (percent by mass), an uppercase letter shall be added as a suffix.
- ◆ The numbers are in chronological order of the refrigerant’s approval by ASHRAE.
- ◆ Examples:
 - ◆ R407A (R32/R125/R134a (20/40/40))
 - ◆ R407B (R32/R125/R134a (10/70/20))
 - ◆ R407C (R32/R125/R134a (23/25/52))
 - ◆ R407D (R32/R125/R134a (15/15/70))
 - ◆ R407E (R32/R125/R134a (25/15/60))

5. Azeotropic blends assigned 500-series numbers

R5xx

- ◆ An azeotrope is defined as a point at which the concentration of the liquid and the vapor phase are the same for a given temperature and pressure.
- ◆ Some mixtures have more than one azeotrope at a fixed pressure or temperature, but this is uncommon.
- ◆ At an azeotrope, a mixture behaves like a single-constituent system.
- ◆ Azeotropes are designated by a three digit number beginning with the number "5".
- ◆ Examples:
 - ◆ R500(R12/152a(73.8/26.2))
 - ◆ R-502 (R22/ R115(48.8/51.2))
 - ◆ R507 (R125/R143a (50/50))

6. Cyclic compounds assigned RC-series numbers RCxxx

- ◆ If the compound is cyclic, then the number is prefixed with "C".
- ◆ Example:
 - ◆ RC316 :C4Cl2F6;
 - ◆ RC317 : C4ClF7;
 - ◆ RC318: C4F8.

7. Organic compounds assigned 600-series numbers

R6xx

- ◆ Miscellaneous organic refrigerants are assigned arbitrary numbers in the 600 series.
- ◆ This includes hydrocarbon refrigerants that cannot be identified by the regular numbering system .
- ◆ Examples:
 - ◆ R600: butane: $CH_3CH_2CH_2CH_3$
 - ◆ R601: isobutene: $CH(CH_3)_3$
 - ◆ R610: ethyl ether: $C_2H_5OC_2H_5$

8. Inorganic compounds blends assigned 700-series numbers *R7xx*

- ◆ Inorganic refrigerants are allocated to the 700 series, using the molecular weight prefixed by the number 7. Lower case suffices are added to denote decreasing symmetry in isomers, or to denote inorganic gases with the same molecular weight.
- ◆ Examples:
 - ◆ R717 corresponds to ammonia NH_3 which has a molecular mass of 17;
 - ◆ R718 corresponds to water;
 - ◆ R729 corresponds to air;
 - ◆ R744: carbon dioxide: CO_2 ;
 - ◆ R744A: nitrous oxide: N_2O

9. Classification of CFCs, HCFCs, HFCs, PFCs, HCs and NIK

- ◆ The name chlorofluorocarbon (CFCs) is applied to a substance formed by replacing all of the hydrogen atoms of a hydrocarbon molecule with chlorine and fluorine (or bromine).
- ◆ Hydrochlorofluorocarbons (HCFCs) are similar to CFC's, but they are only partially halogenated and therefore retain some hydrogen.
- ◆ Hydrofluorocarbons (HFCs) are formed by partially fluorinating hydrocarbons.
- ◆ They retain some hydrogen and are totally chlorine free.

Refrigeration Technology



- ◆ Perfluorocarbons (PFCs) are fully fluorinated hydrocarbons.
- ◆ They are very stable, have excellent fire suppressing properties, but have very long atmospheric lifetimes.
- ◆ Hydrocarbons (HCs) are naturally occurring organic substances.
- ◆ They are generally stable and non-reactive with the exceptions of their flammability and their ability to react with halogens.

7-5. Secondary Refrigerants

- ◆ In some vapor compression refrigeration systems the cooling effect is directly applied to the bodies to be refrigerated from evaporators, which is known as *direct expansion*.
- ◆ In many other cases the refrigeration may be needed are away from the evaporator, or that the evaporator can not setup to the body to be refrigerated, secondary refrigerants are used to distribute the refrigeration.

Refrigeration Technology

- ◆ In this type of arrangement, the secondary refrigerant is cooled by the evaporator and is then the cooled secondary refrigerant is pumped to the place where refrigeration is wanted as shown in Fig.7-5.
- ◆ In these cases the refrigerant inside the evaporator of the refrigeration system is also called the primary refrigerant.

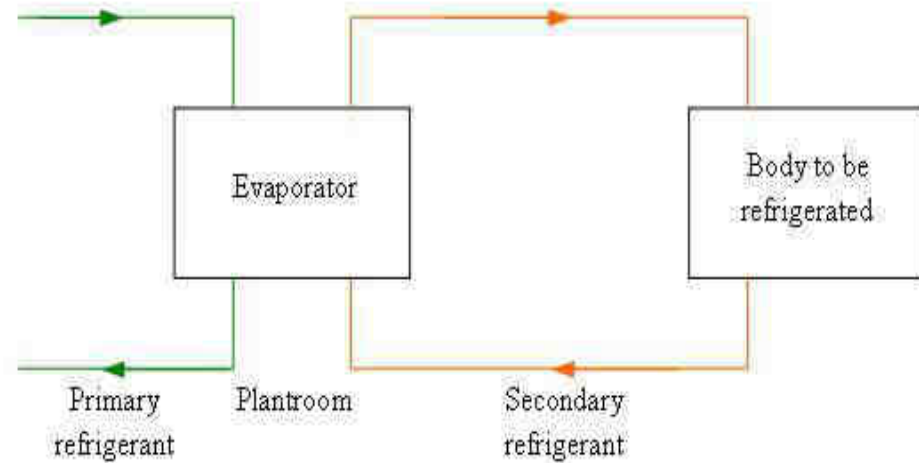

Fig.7-5, The secondary refrigerant used for distribute refrigeration

Refrigeration Technology



- ◆ The secondary refrigerant must remain liquid at the temperature desired.
- ◆ A good secondary refrigerant is expected to:
 - ◆ ① have a sufficiently low freezing point at a not-too-high concentration;
 - ◆ ② be stable and non-corrosive;
 - ◆ ③ be inexpensive;
 - ◆ ④ have good thermal and hydrodynamic characteristics.

Refrigeration Technology



- ◆ **Water**
- ◆ For air conditioning installations, water is a suitable secondary refrigerant.
- ◆ Chilled water at about 6-7 is produced in the refrigeration plant room and distributed to unit coolers or other forms of heat exchanger throughout the building.
- ◆ Water is also used frequently as a secondary refrigerant in industrial and food refrigeration.

Refrigeration Technology



- ◆ **Brines- Solutions of inorganic salts in water**
- ◆ Brine is a name given to a solution by dissolving various salts into water.
- ◆ The freezing point of brine is lower than that of pure water, and the freezing point decreases as the concentration of the salt until the eutectic point is reached

Refrigeration Technology



- ◆ **Pure organic liquids and their aqueous solutions**
- ◆ The freezing point of ethylene glycol aqueous solution at 55% by volume is .
- ◆ The eutectic of propylene glycol aqueous solution is at 60% by volume and its freezing point at 59% by volume is .
- ◆ They are non-corrosive and non-toxic but more expensive.